

Chapters 3 & 4: Integral Relations for a Control Volume and Differential Relations for Fluid Flow

Laws of mechanics are written for a system, i.e., a fixed amount of matter.

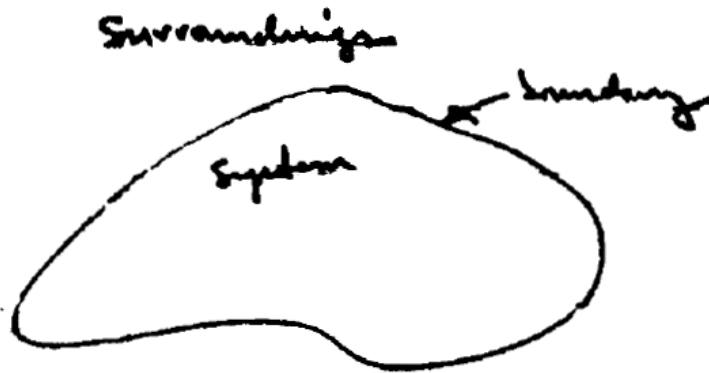

1. Conservation of mass: $\frac{dm}{dt} = 0$

2. Conservation of momentum: $\underline{F} = m\underline{a} = \frac{d(m\underline{v})}{dt}$

3. Conservation of energy: $\frac{dE}{dt} = \dot{Q} - \dot{W}$

$\Delta E = \text{heat added} - \text{work done}$

Also

Conservation of angular momentum: $\frac{dH_G}{dt} = \underline{M}_G$

Second Law of Thermodynamics: $\frac{dS}{dt} = \frac{\delta\dot{Q}}{T} + \dot{\sigma}$

$\dot{\sigma}$, entropy production due to system irreversibilities

$\dot{\sigma} \leq 0$

In fluid mechanics we are usually interested in a region of space, i.e, control volume and not particular systems. Therefore, we need to transform GDE's from a system to a control volume, which is accomplished through the use of

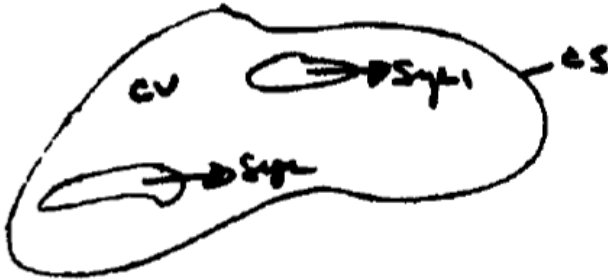

RTT (actually derived in thermodynamics for CV forms of continuity and 1st and 2nd laws, but not in general form or referred to as RTT).

Note GDE's are of form:

$$\frac{d}{dt}(m, m\underline{V}, E) = \text{RHS}$$

system extensive properties B_{sys} depend on mass

i.e., involve $\frac{dB_{\text{sys}}}{dt}$ which needs to be related to changes in CV. Recall, definition of corresponding system intensive properties

$$\beta = (1, \underline{V}, e) \quad \text{independent of mass}$$

where

$$B = \int \beta dm = \int \beta \rho dV$$

$$\text{i.e., } \beta = \frac{dB}{dm}$$

Reynolds Transport Theorem (RTT)

Need relationship between $\frac{d}{dt}(B_{sys})$ and changes in

$$B_{CV} = \int_{CV} \beta dm = \int_{CV} \beta \rho dV.$$

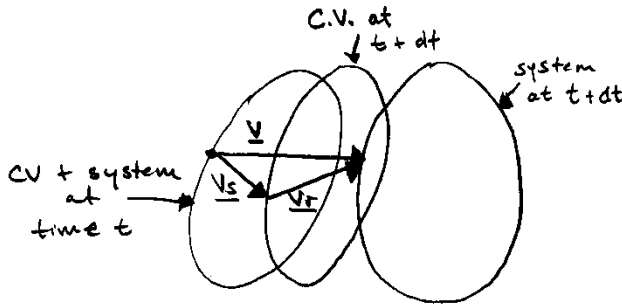

Moving deforming CV:
 $\underline{V}_r = \underline{V} - \underline{V}_s$

\underline{V} = fluid velocity
 \underline{V}_s = CS defining CV velocity
 \underline{V}_r = relative velocity

} all in same coordinate system

$$\frac{dB_{sys}}{dt} = \lim_{\Delta t \rightarrow 0} \frac{(B_{CV} + \Delta B)_{t+\Delta t} - (B_{CV} + \Delta B)_t}{\Delta t}$$

$$= \underbrace{\lim_{\Delta t \rightarrow 0} \frac{B_{CV,t+\Delta t} - B_{CV,t}}{\Delta t}}_{\textcircled{1}} + \underbrace{\lim_{\Delta t \rightarrow 0} \frac{\Delta B_{t+\Delta t} - \Delta B_t}{\Delta t}}_{\textcircled{2}}$$

$$1 = \text{time rate of change of } B \text{ in CV} = \frac{dB_{CV}}{dt} = \frac{d}{dt} \int_{CV} \beta \rho dV$$

$$2 = \text{net outflux of } B \text{ from CV across CS} = \int_{CS} \beta \rho \underline{V}_R \cdot \underline{n} dA$$

As with Q and \dot{m} , $\Delta \dot{B}$ flux through A per unit time is:

$$dQ = \underline{V}_R \cdot \underline{n} dA$$

$$d\dot{m} = \rho \underline{V}_R \cdot \underline{n} dA$$

$$d\Delta \dot{B} = \beta \rho \underline{V}_R \cdot \underline{n} dA$$

Therefore:

$$\frac{dB_{SYS}}{dt} = \frac{d}{dt} \int_{CV} \beta \rho dV + \int_{CS} \beta \rho \underline{V}_R \cdot \underline{n} dA \quad \boxed{\underline{V}_r = \underline{V} - \underline{V}_s}$$

General form RTT for moving deforming control volume.

Specific CV cases depending on $\underline{V}_s(\underline{x}, t)$.

- 1) **Deforming CV**: $\forall = \forall(\underline{x}, t)$
 - (a) $\underline{V}_s = \underline{V}_s(\underline{x}, t)$ non-uniform/**accelerating** velocity
 - (b) $\underline{V}_s = \underline{V}_s(\underline{x})$ uniform/constant velocity (**steady moving**)
 - (c) $\int_{CS} \underline{V}_s(\underline{x}, t) \cdot \underline{n} dA = 0$ as a whole at rest (**stationary**)

- 2) **Non deforming CV**: $\forall \neq \forall(\underline{x})$
 - (a) $\underline{V}_s = \underline{V}_s(t)$ **accelerating** velocity
 - (b) $\underline{V}_s = \text{constant}$ velocity, i.e., relative inertial coordinates (**steady moving**)
 - (c) $\underline{V}_s = 0$ at rest (**stationary**)

- 3) Material volume: $\underline{V}_s = \underline{V}$, $\underline{V}_r = 0$ and RTT takes the form:

$$\frac{dB_{SYS}}{dt} = \frac{d}{dt} \int_{MV} \beta(\underline{x}, t) \rho(\underline{x}, t) dV$$

Which can be written as:

$$\frac{d}{dt} \int_{MV} \beta(\underline{x}, t) \rho(\underline{x}, t) dV = \int_{MV} \frac{\partial(\beta\rho)}{\partial t} dV + \int_{MS} \beta\rho \underline{V} \cdot \underline{n} dA$$

Using Green's theorem: $\int_V \nabla \cdot \underline{b} dV = \int_S \underline{b} \cdot \underline{n} dA$ $\underline{b} = \beta\rho \underline{V}$

$$\frac{d}{dt} \int_{MV} \beta(\underline{x}, t) \rho(\underline{x}, t) dV = \int_{MV} \left[\frac{\partial(\beta\rho)}{\partial t} + \nabla \cdot (\beta\rho \underline{V}) \right] dV$$

And taking the limit for $dV \rightarrow 0$ provides GDE:

$$\frac{d}{dt} \int_{MV} \beta\rho dV = \frac{\partial(\beta\rho)}{\partial t} + \nabla \cdot (\beta\rho \underline{V})$$

Continuity Equation:

$B = m = \text{mass of system}$

$\beta = 1$

$\frac{dm}{dt} = 0$ by definition, system = fixed amount of mass

- 1) Most general integral form for **deforming** accelerating/steady moving/stationary CV depending on definition $\underline{V}_s(\underline{x}, t)$ (a) – (c) page 4:

$$\frac{dm}{dt} = 0 = \frac{d}{dt} \int_{CV} \rho(\underline{x}, t) dV + \int_{CS} \rho(\underline{x}, t) \underbrace{\left(\underline{V}(\underline{x}, t) - \underline{V}_s(\underline{x}, t) \right)}_{\underline{V}_r} \cdot \underline{n} dA$$

$$-\frac{d}{dt} \int_{CV} \rho dV = \int_{CS} \rho \underline{V}_r \cdot \underline{n} dA$$

Rate of decrease of mass in CV = net rate of mass outflow across CS

- 2) Most general integral form for **non-deforming** $\underline{V}_s \neq \underline{V}_s(x)$ accelerating/steady moving/stationary CV, (a)-(c) page 4:

$$\int_{CV} \frac{\partial \rho(\underline{x}, t)}{\partial t} dV + \int_{CS} \rho(\underline{x}, t) \underbrace{\left(\underline{V}(\underline{x}, t) - \underline{V}_s(t) \right)}_{\underline{V}_r} \cdot \underline{n} dA = 0$$

3) **Incompressible flow** $\rightarrow \rho(\underline{x}, t) = \text{constant}$.

(a) **Deforming** CV accelerating/steady moving/stationary, i.e., conservation of volume:

$$-\frac{d}{dt} \int_{CV} dV = \int_{CS} \underbrace{\left(\underline{V}(\underline{x}, t) - \underline{V}_s(\underline{x}, t) \right)}_{\underline{V}_r} \cdot \underline{n} dA$$

(b) **Non-deforming** CV accelerating/steady moving/stationary:

$$\int_{CS} \underbrace{\left(\underline{V}(\underline{x}, t) - \underline{V}_s(t) \right)}_{\underline{V}_r} \cdot \underline{n} dA = 0$$

(c) **Steady flow**, i.e., $\frac{\partial}{\partial t} = 0$. Two possibilities for \underline{V}_s : $\underline{V}_s = 0$, $\underline{V}_s = \text{constant}$. The RTT takes the form:

$$\int_{CS} \underbrace{\left(\underline{V}(\underline{x}) - \underline{V}_s \right)}_{\underline{V}_r} \cdot \underline{n} dA = 0$$

(d) Flow over **discrete inlet/outlet** \rightarrow the flux term can be expressed as summation:

$$\sum Q_{CS_i} = 0 \text{ or } \sum (Q)_{CS_{in}} = \sum (Q)_{CS_{out}}$$

For inlets:
 $\underline{V}_r \cdot \underline{n} < 0$
 For outlets:
 $\underline{V}_r \cdot \underline{n} > 0$

Non-uniform flow:

$$Q_{CS_i} = \int_{CS} \underbrace{\left(\underline{V}(\underline{x}) - \underline{V}_s \right)}_{\underline{V}_r} \cdot \underline{n} dA = (V_{av} A)_{CS_i}$$

$$V_{av} = \frac{1}{A} \int_{CS} \underbrace{\left(\underline{V}(\underline{x}) - \underline{V}_s \right)}_{\underline{V}_r} \cdot \underline{n} dA$$

Uniform flow:

$$Q_{CS_i} = \left(\underline{V}(\underline{x}) - \underline{V}_s \right) \cdot \underline{n} A$$

For fixed CV, $\underline{V}_s = 0$:
 $Q_{CS_i} = \underline{V}(\underline{x}) \cdot \underline{n} A$

Differential Form:

$$\frac{dm}{dt} = 0 = \int_{MV} \left[\frac{\partial \rho}{\partial t} + \nabla \cdot (\rho \underline{V}) \right] dV$$

$$\beta = 1$$

$$\frac{\partial \rho}{\partial t} + \nabla \cdot (\rho \underline{V}) = 0$$

$$\frac{\partial \rho}{\partial t} + \rho \nabla \cdot \underline{V} + \underline{V} \cdot \nabla \rho = 0$$

$$\frac{D\rho}{Dt} + \rho \nabla \cdot \underline{V} = 0$$

$$m = \rho \nabla \Rightarrow dm = \rho d\nabla + \nabla d\rho = 0 \Rightarrow -\frac{d\nabla}{\nabla} = \frac{d\rho}{\rho}$$

$$\frac{1}{\rho} \frac{D\rho}{Dt} = -\frac{1}{\nabla} \frac{D\nabla}{Dt}$$

$$\underbrace{\frac{1}{\rho} \frac{D\rho}{Dt}}_{\substack{\text{rate of change } \rho \\ \text{per unit } \rho}} + \underbrace{\nabla \cdot \underline{V}}_{\substack{\text{rate of change } \nabla \\ \text{per unit } \nabla}} = 0$$

$$\frac{\partial u}{\partial x} + \frac{\partial v}{\partial y} + \frac{\partial w}{\partial z} = -\frac{1}{\rho} \frac{D\rho}{Dt} = \frac{1}{\nabla} \frac{D\nabla}{Dt}$$

Called the continuity equation since the implication is that ρ and \underline{V} are continuous functions of \underline{x} .

Incompressible Fluid: $\rho = \text{constant}$

$$\nabla \cdot \underline{V} = 0$$

$$\frac{\partial u}{\partial x} + \frac{\partial v}{\partial y} + \frac{\partial w}{\partial z} = 0$$

P3.15 Water, assumed incompressible, flows steadily through the round pipe in Fig. P3.15. The entrance velocity is constant, $u = U_0$, and the exit velocity approximates turbulent flow, $u = u_{\max} (1 - r/R)^{1/7}$. Determine the ratio U_0/u_{\max} for this flow.

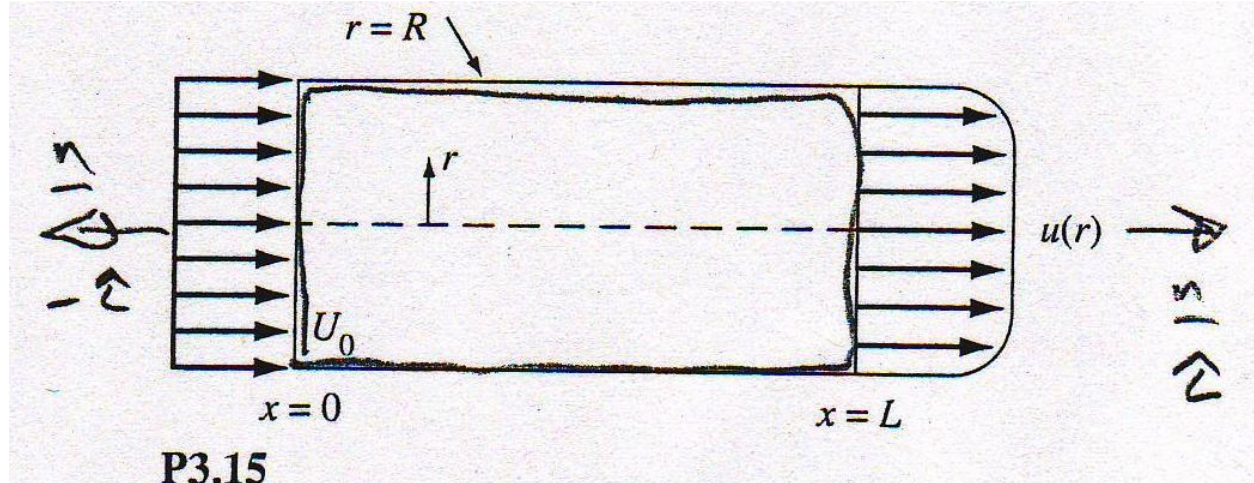

Steady flow, non-deforming, fixed CV, one inlet uniform flow and one outlet non-uniform flow

$$-\dot{m}_{in} + \dot{m}_{out} = 0; \quad \rho = \text{constant}; \quad -Q_{in} + Q_{out} = 0$$

$$0 = -U_0 \pi R^2 + \int_0^R u_{\max} (1 - r/R)^{1/7} 2\pi r dr$$

$$0 = -U_0 \pi R^2 + u_{\max} \frac{49\pi}{60} R^2$$

$$\frac{U_0}{u_{\max}} = \frac{49}{60}$$

$$2\pi u_{\max} \int_0^R \left(1 - \frac{r}{R}\right)^{1/7} r dr = 2\pi u_{\max} \left[\frac{1}{R^2 \left(\frac{1}{7} + 2\right)} (1 - r/R)^{15/7} - \frac{1}{R^2 \left(\frac{1}{7} + 1\right)} (1 - r/R)^{8/7} \right]_0^R$$

$$= 2\pi u_{\max} R^2 \left[0 - \left(\frac{7}{15} - \frac{7}{8} \right) \right] = \pi u_{\max} R^2 \frac{49}{60}$$

P3.12 The pipe flow in Fig. P3.12 fills a cylindrical tank as shown. At time $t=0$, the water depth in the tank is 30cm. Estimate the time required to fill the remainder of the tank.

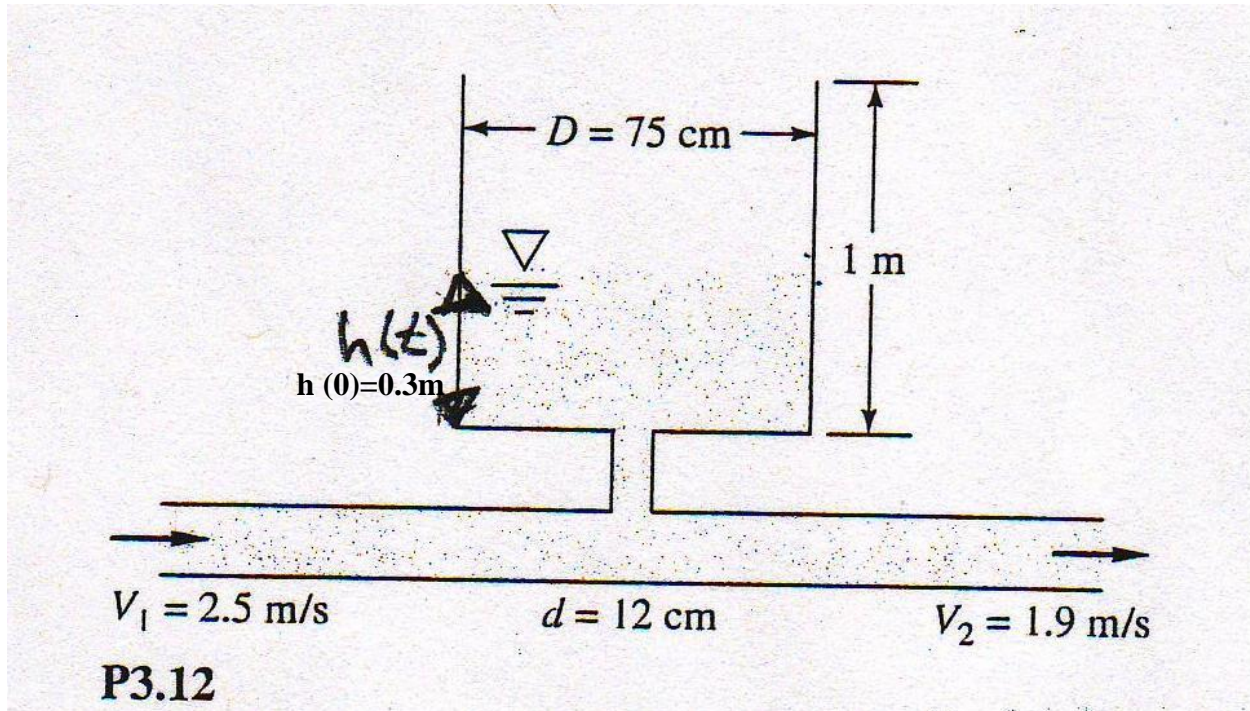

Unsteady flow, deforming CV, one inlet one outlet with uniform flow

$$0 = \frac{d}{dt} \int_{CV} \rho d\forall - \rho Q_1 + \rho Q_2$$

$$0 = \frac{d}{dt} \int_{CV} \rho d\forall - \rho V_1 \frac{\pi d^2}{4} + \rho V_2 \frac{\pi d^2}{4}$$

$$\forall(t) = h(t) \frac{\pi D^2}{4}$$

$$0 = \frac{\rho\pi D^2}{4} \frac{dh}{dt} + \rho \frac{\pi d^2}{4} (V_2 - V_1)$$

$$\frac{dh}{dt} = \left(\frac{d}{D}\right)^2 (V_1 - V_2) = 0.0153$$

$$dt = \frac{dh}{0.0153} = \frac{0.7}{0.0153} = 46s$$

Steady flow, fixed CV with one inlet and two exits with uniform flow

$$\text{Note: } Q = \int_A \underline{V} \cdot \underline{n} dA = \frac{\forall}{dt} \frac{L^3}{s}$$

$$0 = -Q_1 + Q_2 + Q_3$$

$$Q_3 = \frac{\forall}{dt} = Q_1 - Q_2 = \frac{\pi d^2}{4} (V_1 - V_2)$$

$$dt = \frac{\forall}{Q_3} = \frac{dh \frac{\pi D^2}{4}}{\frac{\pi d^2}{4} (V_1 - V_2)}$$

$$= \frac{dh \left(\frac{D}{d}\right)^2}{(V_1 - V_2)}$$

P4.17 A reasonable approximation for the two-dimensional incompressible laminar boundary layer on the flat surface in Fig.P4.17 is $u = U \left(\frac{2y}{\delta} - \frac{y^2}{\delta^2} \right)$ for $y \leq \delta$,

where $\delta = Cx^{1/2}$, $C = const$

- (a) Assuming a no-slip condition at the wall, find an expression for the velocity component $v(x, y)$ for $y \leq \delta$.
- (b) Find the maximum value of v at the station $x = 1m$, for the particular case of flow, when $U = 3m/s$ and $\delta = 1.1cm$.

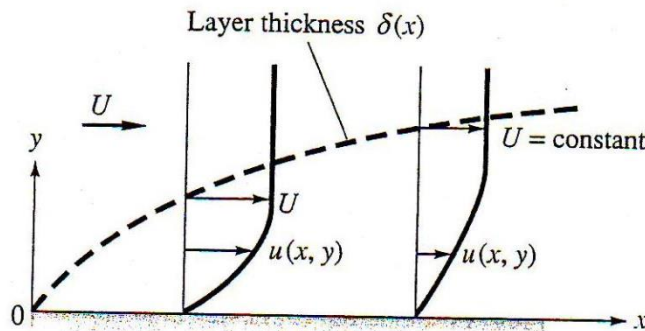

P4.17

$$\frac{\partial u}{\partial x} + \frac{\partial v}{\partial y} = 0$$

$$\frac{\partial v}{\partial y} = -\frac{\partial u}{\partial x} = -U \left(-2y\delta^{-2} + 2y^2\delta^{-3} \right) \frac{\partial \delta}{\partial x}$$

$$v = 2U \delta_x \int_0^y \left(y\delta^{-2} - y^2\delta^{-3} \right) dy$$

$$\frac{\partial u}{\partial x} = \frac{\partial u}{\partial \delta} \frac{\partial \delta}{\partial x}$$

$$\delta_x = \frac{\partial \delta}{\partial x}$$

(a) $v = 2U \delta_x \left(\frac{y^2}{2\delta^2} - \frac{y^3}{3\delta^3} \right)$ $\delta = Cx^{1/2}$ $\delta_x = \frac{C}{2} x^{-1/2} = \frac{\delta}{2x}$

(b) Since $v_y = 0$ at $y = \delta$

$$v_{\max} = v(y = \delta) = \frac{2U\delta}{2x} \left(\frac{1}{2} - \frac{1}{3} \right) = \frac{U\delta}{6x} = \frac{3 \times 0.011}{6} = 0.0055 \text{ m/s}$$

Momentum Equation:

$B = m\underline{V} = \text{momentum}, \beta = \underline{V}$

Integral Form:

$$\frac{d(m\underline{V})}{dt} = \underbrace{\frac{d}{dt} \int_{CV} \underline{V} \rho \, d\underline{\nabla}}_1 + \underbrace{\int_{CS} \underline{V} \rho \underline{V}_R \cdot \underline{n} \, dA}_2 = \underbrace{\sum \underline{F}}_3$$

$\sum \underline{F} =$ vector sum of all forces acting on CV

$= \underline{F}_B + \underline{F}_s$

$\underline{F}_B =$ Body forces, which act on entire CV of fluid due to external force field such as gravity or electrostatic or magnetic forces. Force per unit volume.

$\underline{F}_s =$ Surface forces, which act on entire CS due to normal (pressure and viscous stress) and tangential (viscous stresses) stresses. Force per unit area.

When CS cuts through solids \underline{F}_s may also include $\underline{F}_R =$ reaction forces, e.g., reaction force required to hold nozzle or bend when CS cuts through bolts holding nozzle/bend in place.

1 = rate of change of momentum in CV

2 = rate of outflux of momentum across CS

3 = vector sum of all body forces acting on entire CV and surface forces acting on entire CS.

Many interesting applications of CV form of momentum equation: vanes, nozzles, bends, rockets, forces on bodies, water hammer, etc.

Differential Form:

$$\int_{MV} \left[\frac{\partial}{\partial t} (\underline{V}\rho) + \nabla \cdot (\underline{V}\rho\underline{V}) \right] dV = \sum \underline{F}$$

Where $\frac{\partial}{\partial t} (\underline{V}\rho) = \underline{V} \frac{\partial \rho}{\partial t} + \rho \frac{\partial \underline{V}}{\partial t}$

and $\underline{V}\rho\underline{V} = \rho\underline{V}\underline{V} = \rho u \hat{i} \underline{V} + \rho v \hat{j} \underline{V} + \rho w \hat{k} \underline{V}$ is a tensor.

$$\begin{aligned} \nabla \cdot (\underline{V}\rho\underline{V}) &= \nabla \cdot (\rho\underline{V}\underline{V}) = \frac{\partial}{\partial x} (\rho u \underline{V}) + \frac{\partial}{\partial y} (\rho v \underline{V}) + \frac{\partial}{\partial z} (\rho w \underline{V}) \\ &= \underline{V} \nabla \cdot (\rho \underline{V}) + \rho \underline{V} \cdot \nabla \underline{V} \end{aligned}$$

$$\int_{CV} \left[\underline{V} \left(\frac{\partial \rho}{\partial t} + \nabla \cdot (\rho \underline{V}) \right) + \rho \left(\frac{\partial \underline{V}}{\partial t} + \underline{V} \cdot \nabla \underline{V} \right) \right] dV = \sum \underline{F}$$

Since $\frac{\partial \underline{V}}{\partial t} + \underline{V} \cdot \nabla \underline{V} = \frac{D\underline{V}}{Dt}$ = 0, continuity

$$\int_{CV} \rho \frac{D\underline{V}}{Dt} dV = \sum \underline{F}$$

$$\rho \frac{D\underline{V}}{Dt} = \sum \underline{f} \quad \text{per elemental fluid volume}$$

$$\rho \underline{a} = \underline{f}_b + \underline{f}_s$$

\underline{f}_b = body force per unit volume

$\underline{f}_s =$ surface force per unit volume

Body forces are due to external fields such as gravity or magnetic fields. Here we only consider a gravitational field; that is,

$$\sum \underline{F}_{body} = d \underline{F}_{grav} = \rho \underline{g} dx dy dz$$

and $\underline{g} = -g \hat{k}$ for $\downarrow g \quad \uparrow z$
 i.e. $\underline{f}_{body} = -\rho g \hat{k}$

Surface Forces are due to the stresses that act on the sides of the control surfaces

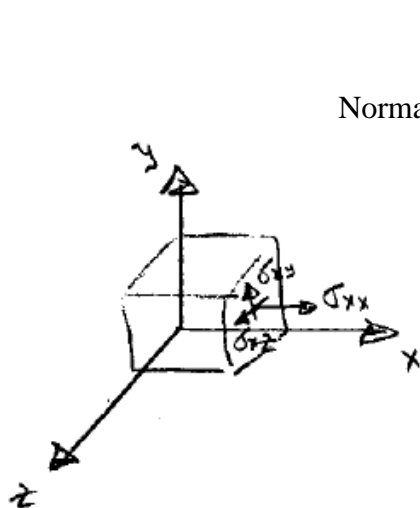

$$\sigma_{ij} = \underbrace{-p \delta_{ij}}_{\text{Normal pressure}} + \underbrace{\tau_{ij}}_{\text{Viscous stress}}$$

$$= \begin{bmatrix} -p + \tau_{xx} & \tau_{xy} & \tau_{xz} \\ \tau_{yx} & -p + \tau_{yy} & \tau_{yz} \\ \tau_{zx} & \tau_{zy} & -p + \tau_{zz} \end{bmatrix}$$

Symmetric $\sigma_{ij} = \sigma_{ji}$

2nd order tensor

Symmetry condition from requirement that for elemental fluid volume, stresses themselves cause no rotation.

As shown before, for p alone it is not the stresses themselves that cause a net force but their gradients.

$$\underline{f}_s = \underline{f}_p + \underline{f}_\tau$$

Recall $\underline{f}_p = -\nabla p$ based on 1st order TS. \underline{f}_τ is more complex since τ_{ij} is a 2nd order tensor, but similarly as for p, the force is due to stress gradients and is derived based on 1st order TS.

$$\begin{aligned} \underline{\sigma}_x &= \sigma_{xx} \hat{i} + \sigma_{xy} \hat{j} + \sigma_{xz} \hat{k} \\ \underline{\sigma}_y &= \sigma_{yx} \hat{i} + \sigma_{yy} \hat{j} + \sigma_{yz} \hat{k} \\ \underline{\sigma}_z &= \sigma_{zx} \hat{i} + \sigma_{zy} \hat{j} + \sigma_{zz} \hat{k} \end{aligned} \quad \begin{array}{l} \text{Resultant} \\ \text{stress} \\ \text{on each face} \end{array}$$

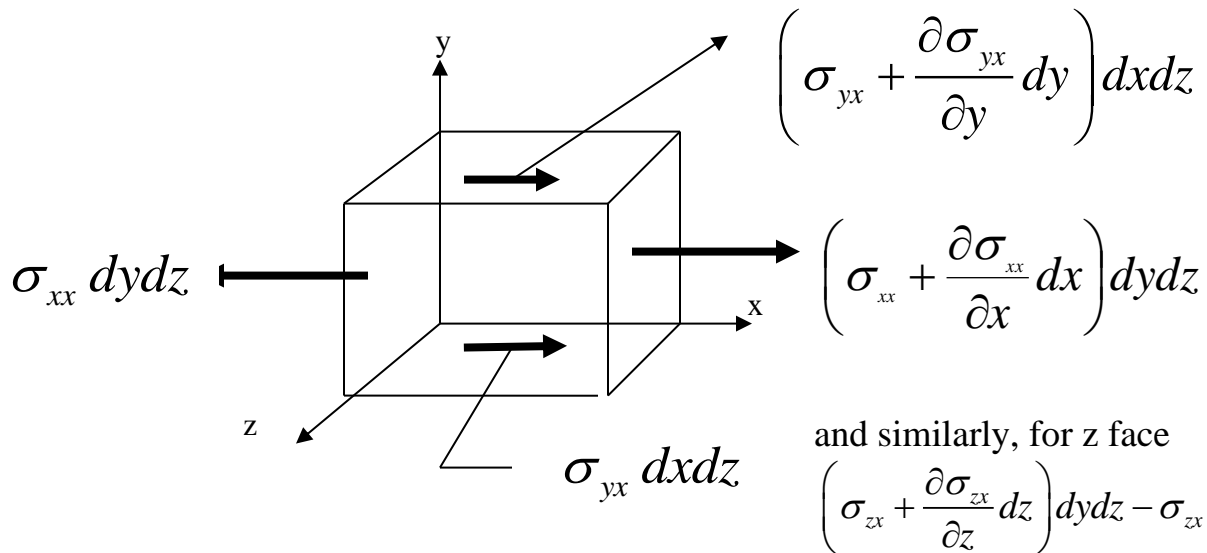

and \hat{j} and \hat{k} directions

$$\begin{aligned} \underline{F}_s &= \left[\frac{\partial}{\partial x} (\sigma_{xx}) + \frac{\partial}{\partial y} (\sigma_{yx}) + \frac{\partial}{\partial z} (\sigma_{zx}) \right] dx dy dz \hat{i} \\ &+ \left[\frac{\partial}{\partial x} (\sigma_{xy}) + \frac{\partial}{\partial y} (\sigma_{yy}) + \frac{\partial}{\partial z} (\sigma_{zy}) \right] dx dy dz \hat{j} \end{aligned}$$

$$+ \left[\frac{\partial}{\partial x} (\sigma_{xz}) + \frac{\partial}{\partial y} (\sigma_{yz}) + \frac{\partial}{\partial z} (\sigma_{zz}) \right] dx dy dz \hat{k}$$

$$\underline{F_s} = \left[\frac{\partial}{\partial x} (\underline{\sigma_x}) + \frac{\partial}{\partial y} (\underline{\sigma_y}) + \frac{\partial}{\partial z} (\underline{\sigma_z}) \right] dx dy dz$$

Divided by the volume:

$$\underline{f_s} = \frac{\partial}{\partial x} (\underline{\sigma_x}) + \frac{\partial}{\partial y} (\underline{\sigma_y}) + \frac{\partial}{\partial z} (\underline{\sigma_z})$$

$$\underline{f_s} = (f_{s_1}, f_{s_2}, f_{s_3}) = f_{s_i} = \nabla \cdot \sigma_{ij} = \frac{\partial}{\partial x_j} \sigma_{ij}$$

Since $\sigma_{ij} = \sigma_{ji}$

According to Einstein summation notation, repeated indices are implicitly summed over:

$$\sigma_{ii} = \sigma_{11} + \sigma_{22} + \sigma_{33}$$

Putting together the above results,

$$\rho \underline{a} = \rho \frac{DV}{Dt} = -\rho g \hat{k} + \nabla \cdot \sigma_{ij}$$

Inertial force
body force due to gravity
surface force = p + viscous terms (Due to stress gradients)

Note:

Δ = delta

∇ = nabla (Hebrew “nebel” means lyre or ancient harp used by David to entertain King Saul in praise of God)

∇f = vector

$\nabla \cdot f$ = scalar

$\nabla \cdot \sigma_{ij}$ = vector (decreases 2nd order tensor by one)

$\nabla f =$ tensor

$\nabla \times \underline{V} =$ vector

Next, we need to relate the stresses σ_{ij} to the fluid motion, i.e., the velocity field. To this end, we examine the relative motion between two neighboring fluid particles.

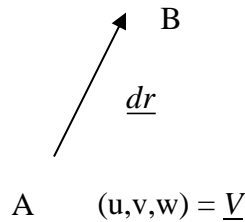

@ B: $\underline{V} + d\underline{V} = \underline{V} + \nabla \underline{V} \cdot d\underline{r}$ 1st order Taylor Series

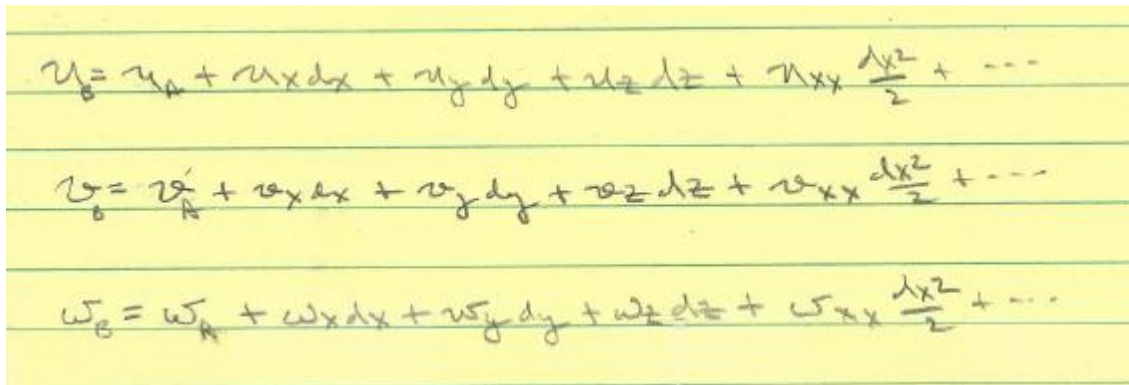

$d\underline{V} = (u_B - u_A, v_B - v_A, w_B - w_A)$

$d\underline{V} = \nabla \underline{V} \cdot d\underline{r} = \begin{bmatrix} u_x & u_y & u_z \\ v_x & v_y & v_z \\ w_x & w_y & w_z \end{bmatrix} \begin{bmatrix} dx \\ dy \\ dz \end{bmatrix} = e_{ij} dx_j$

↑ relative motion deformation rate

$d\underline{V} = dV_i = (dV_1, dV_2, dV_3)$

tensor = e_{ij}

$$e_{ij} = \frac{\partial u_i}{\partial x_j} = \underbrace{\frac{1}{2} \left(\frac{\partial u_i}{\partial x_j} + \frac{\partial u_j}{\partial x_i} \right)}_{\substack{\text{symmetric part} \\ \varepsilon_{ij} = \varepsilon_{ji}}} + \underbrace{\frac{1}{2} \left(\frac{\partial u_i}{\partial x_j} - \frac{\partial u_j}{\partial x_i} \right)}_{\substack{\text{anti-symmetric part} \\ \omega_{ij} = -\omega_{ji}}} = \varepsilon_{ij} + \omega_{ij}$$

$$\omega_{ij} = \begin{bmatrix} 0 & \frac{1}{2}(u_y - v_x) & \overbrace{\frac{1}{2}(u_z - w_x)}^{\eta} \\ \underbrace{\frac{1}{2}(v_x - u_y)}_{\zeta} & 0 & \frac{1}{2}(v_z - w_y) \\ \frac{1}{2}(w_x - u_z) & \underbrace{\frac{1}{2}(w_y - v_z)}_{\xi} & 0 \end{bmatrix} = \text{rigid body rotation of fluid element}$$

where $\xi =$ rotation about x axis
 $\eta =$ rotation about y axis
 $\zeta =$ rotation about z axis

Note that the components of ω_{ij} are related to the vorticity vector defined by:

$$\underline{\omega} = \nabla \times \underline{V} = \underbrace{(w_y - v_z)}_{2\xi} \hat{i} + \underbrace{(u_z - w_x)}_{2\eta} \hat{j} + \underbrace{(v_x - u_y)}_{2\zeta} \hat{k} = \omega_x \hat{i} + \omega_y \hat{j} + \omega_z \hat{k}$$

$= 2 \times$ angular velocity of fluid element

ε_{ij} = rate of strain tensor

$$= \begin{bmatrix} u_x & \frac{1}{2}(u_y + v_x) & \frac{1}{2}(u_z + w_x) \\ \frac{1}{2}(v_x + u_y) & v_y & \frac{1}{2}(v_z + w_y) \\ \frac{1}{2}(w_x + u_z) & \frac{1}{2}(w_y + v_z) & w_z \end{bmatrix}$$

$u_x + v_y + w_z = \nabla \cdot \underline{V} = \text{elongation (or volumetric dilatation)}$

of fluid element $= \frac{1}{\nabla} \frac{D\nabla}{Dt}$

$\frac{1}{2}(u_y + v_x) = \text{distortion wrt (x,y) plane}$

$\frac{1}{2}(u_z + w_x) = \text{distortion wrt (x,z) plane}$

$\frac{1}{2}(v_z + w_y) = \text{distortion wrt (y,z) plane}$

Thus, general motion consists of:

- 1) pure translation described by \underline{V}
- 2) rigid-body rotation described by $\underline{\omega}$
- 3) volumetric dilatation described by $\nabla \cdot \underline{V}$
- 4) distortion in shape described by $\varepsilon_{ij} \quad i \neq j$

It is now necessary to make certain postulates concerning the relationship between the fluid stress tensor (σ_{ij}) and rate-of-deformation tensor (e_{ij}). These postulates are based on physical reasoning and experimental observations and have been verified experimentally even for extreme conditions. For a Newtonian fluid:

- 1) When the fluid is at rest the stress is hydrostatic and the pressure is the thermodynamic pressure
- 2) Since there is no shearing action in rigid body rotation, it causes no shear stress.
- 3) τ_{ij} is linearly related to ε_{ij} and only depends on ε_{ij} .
- 4) There is no preferred direction in the fluid, so that the fluid properties are point functions (condition of isotropy).

Using statements 1-3

$$\sigma_{ij} = -p\delta_{ij} + k_{ijmn}\epsilon_{mn} \quad \epsilon_{ij} = \frac{1}{2}\left(\frac{\partial u_i}{\partial x_j} + \frac{\partial u_j}{\partial x_i}\right)$$

k_{ijmn} = 4th order tensor with 81 components (3x3x3x3) such that each stress is linearly related to all nine components of ϵ_{mn} .

However, statement (4) requires that the fluid has no directional preference, i.e., σ_{ij} is independent of rotation of the coordinate system, which means k_{ijmn} is an isotropic tensor = 4th order tensor made up of products of δ_{ij} .

$$k_{ijmn} = \lambda\delta_{ij}\delta_{mn} + \mu\delta_{im}\delta_{jn} + \gamma\delta_{in}\delta_{jm}$$

$$(\lambda, \mu, \gamma) = \text{scalars}$$

Lastly, the symmetry condition $\sigma_{ij} = \sigma_{ji}$ requires:

$$k_{ijmn} = k_{jimn}$$

$$k_{ijmn} = \lambda\delta_{ij}\delta_{mn} + \mu\delta_{im}\delta_{jn} + \gamma\delta_{in}\delta_{jm}$$

$$k_{jimn} = \lambda\delta_{ji}\delta_{mn} + \mu\delta_{jm}\delta_{in} + \gamma\delta_{jn}\delta_{im}$$

Equating the two:

$$\begin{aligned} \lambda\delta_{ij}\delta_{mn} + \mu\delta_{im}\delta_{jn} + \gamma\delta_{in}\delta_{jm} \\ = \lambda\delta_{ji}\delta_{mn} + \mu\delta_{jm}\delta_{in} + \gamma\delta_{jn}\delta_{im} \end{aligned}$$

$$\lambda\delta_{mn}(\delta_{ij} - \delta_{ji}) + \mu(\delta_{im}\delta_{jn} - \delta_{jm}\delta_{in}) + \gamma(\delta_{in}\delta_{jm} - \delta_{jn}\delta_{im}) = 0$$

The first term is zero since $\delta_{ij} = \delta_{ji}$, therefore:

$$\mu(\delta_{im}\delta_{jn} - \delta_{jm}\delta_{in}) + \gamma(\delta_{in}\delta_{jm} - \delta_{jn}\delta_{im}) = 0$$

If $i = m$ and $j = n$:

$$\mu(1 - \delta_{nm}\delta_{mn}) - \gamma(1 - \delta_{mn}\delta_{nm}) = 0$$

If $j = m$ and $i = n$:

$$\mu(\delta_{nm}\delta_{mn} - 1) - \gamma(\delta_{mn}\delta_{nm} - 1) = 0$$

i.e.,

$$\mu = \gamma = \text{viscosity}$$

The stress tensor can be written as:

$$\sigma_{ij} = -p\delta_{ij} + \mu\delta_{im}\delta_{jn}\varepsilon_{mn} + \mu\delta_{in}\delta_{jm}\varepsilon_{mn} + \lambda\delta_{ij}\delta_{mn}\varepsilon_{mn}$$

Take $\mu\delta_{im}\delta_{jn}\varepsilon_{mn} \rightarrow \delta_{im} \neq 0$ if $m = i$ and $\delta_{jn} \neq 0$ if $n = j \rightarrow$ equivalent to $\mu\varepsilon_{ij}$. Similar reasoning for other terms:

$$\sigma_{ij} = -p\delta_{ij} + 2\mu\varepsilon_{ij} + \lambda \underbrace{\varepsilon_{mm}}_{\nabla \cdot \underline{V}} \delta_{ij}$$

λ and μ can be further related if one considers mean normal stress vs. thermodynamic p .

$$\sigma_{xx} + \sigma_{yy} + \sigma_{zz} = \sigma_{ii} = -3p + (2\mu + 3\lambda)\nabla \cdot \underline{V}$$

$$p = \underbrace{-\frac{1}{3}\sigma_{ii}}_{\substack{\bar{p} = \text{mean} \\ \text{normal stress}}} + \left(\frac{2}{3}\mu + \lambda\right)\nabla \cdot \underline{V}$$

$$p - \bar{p} = \left(\frac{2}{3}\mu + \lambda\right)\nabla \cdot \underline{V}$$

Incompressible flow: $p = \bar{p}$ and absolute pressure is indeterminate since there is no equation of state for p . Equations of motion determine ∇p .

Compressible flow: $p \neq \bar{p}$ and $\lambda =$ bulk viscosity which must be determined; however, it is a very difficult measurement requiring large $\nabla \cdot \underline{V} = -\frac{1}{\rho} \frac{D\rho}{Dt} = \frac{1}{\nabla} \frac{D\nabla}{Dt}$, e.g., within shock waves.

Stokes Hypothesis also supported kinetic theory monotonic gas.

$$\lambda = -\frac{2}{3}\mu$$

$$p = \bar{p}$$

$$\sigma_{ij} = -\left(p + \frac{2}{3} \mu \nabla \cdot \underline{V} \right) \delta_{ij} + 2\mu \varepsilon_{ij}$$

Generalization $\tau = \mu \frac{du}{dy}$ for 3D flow.

$$\tau_{ij} = \mu \left(\frac{\partial u_i}{\partial x_j} + \frac{\partial u_j}{\partial x_i} \right) \quad i \neq j \quad \text{relates shear stress to strain rate}$$

$$\sigma_{ii} = -p - \frac{2}{3} \mu \nabla \cdot \underline{V} + 2\mu \left(\frac{\partial u_i}{\partial x_i} \right) = -p + \underbrace{2\mu \left[-\frac{1}{3} \nabla \cdot \underline{V} + \frac{\partial u_i}{\partial x_i} \right]}_{\text{normal viscous stress}}$$

Where the normal viscous stress is the difference between the extension rate in the x_i direction and average expansion at a point. Only differences from the average = $\frac{1}{3} \left(\frac{\partial u}{\partial x} + \frac{\partial v}{\partial y} + \frac{\partial w}{\partial z} \right)$ generate normal viscous stresses. For incompressible fluids, average = 0 i.e., $\nabla \cdot \underline{V} = 0$.

Non-Newtonian fluids:

$\tau_{ij} \propto \varepsilon_{ij}$ for small strain rates $\dot{\theta}$, which works well for air, water, etc. Newtonian fluids

$$\tau_{ij} \propto \underbrace{\varepsilon_{ij}^n}_{\text{non-linear}} + \underbrace{\frac{\partial}{\partial t} \varepsilon_{ij}}_{\text{history effect}} \quad \text{Non-Newtonian}$$

Viscoelastic materials

Non-Newtonian fluids include:

- (1) Polymer molecules with large molecular weights and form long chains coiled together in spongy ball shapes that deform under shear.
- (2) Emulsions and slurries containing suspended particles such as blood and water/clay.

Navier Stokes Equations:

$$\rho \underline{a} = \rho \frac{DV}{Dt} = -\rho g \hat{k} + \nabla \cdot \sigma_{ij}$$

$$\rho \frac{DV}{Dt} = -\rho g \hat{k} - \nabla p + \frac{\partial}{\partial x_j} \left[2\mu \varepsilon_{ij} - \frac{2}{3} \mu \nabla \cdot \underline{V} \delta_{ij} \right]$$

Recall $\mu = \mu(T)$ and μ increases with T for gases, decreases with T for liquids, but if it is assumed that $\mu =$ constant:

$$\rho \frac{DV}{Dt} = -\rho g \hat{k} - \nabla p + 2\mu \frac{\partial}{\partial x_j} \varepsilon_{ij} - \frac{2}{3} \mu \frac{\partial}{\partial x_j} \nabla \cdot \underline{V}$$

$$2 \frac{\partial}{\partial x_j} \varepsilon_{ij} = \frac{\partial}{\partial x_j} \left(\frac{\partial u_i}{\partial x_j} + \frac{\partial u_j}{\partial x_i} \right) = \frac{\partial^2 u_i}{\partial x_j \partial x_j} = \nabla^2 u_i = \nabla^2 \underline{V}$$

$$\rho \frac{D\underline{V}}{Dt} = -\rho g \hat{k} - \nabla p + \mu \left[\nabla^2 \underline{V} - \frac{2}{3} \frac{\partial}{\partial x_j} \nabla \cdot \underline{V} \right]$$

For incompressible flow $\nabla \cdot \underline{V} = 0$

$$\rho \frac{D\underline{V}}{Dt} = \underbrace{-\rho g \hat{k} - \nabla p}_{-\nabla \hat{p} \text{ where } \hat{p} = p + \gamma z \text{ piezometric pressure}} + \mu \nabla^2 \underline{V}$$

For $\mu = 0$

$$\rho \frac{D\underline{V}}{Dt} = -\rho g \hat{k} - \nabla p \quad \text{Euler Equation}$$

NS equations for ρ, μ constant

$$\rho \frac{D\underline{V}}{Dt} = -\nabla \hat{p} + \mu \nabla^2 \underline{V}$$

$$\rho \left[\frac{\partial \underline{V}}{\partial t} + \underline{V} \cdot \nabla \underline{V} \right] = -\nabla \hat{p} + \mu \nabla^2 \underline{V}$$

$$\left[\frac{\partial \underline{V}}{\partial t} + \underline{V} \cdot \nabla \underline{V} \right] = -\frac{1}{\rho} \nabla \hat{p} + \nu \nabla^2 \underline{V} \quad \nu = \frac{\mu}{\rho} \text{ kinematic viscosity/} \\ \text{diffusion coefficient}$$

Non-linear 2nd order PDE, as is the case for ρ, μ not constant.

Combine with $\nabla \cdot \underline{V}$ for 4 equations for 4 unknowns \underline{V}, p and can be, albeit difficult, solved subject to initial and boundary conditions for \underline{V}, p at $t = t_0$ and on all boundaries i.e. “well posed” IBVP.

Application of CV Momentum Equation:

$$\underbrace{\sum \underline{F}}_{\text{net force on CV}} = \underbrace{\frac{d}{dt} \int_{CV} \underline{V} \rho dV}_{\text{time rate of change of momentum in CV}} + \underbrace{\int_{CS} \underline{V} \rho \underline{V}_R \cdot \underline{n} dA}_{\text{net momentum outflux}}$$

$$\underline{F} = \underline{F}_B + \underline{F}_S \quad (\underline{F}_S \text{ includes reaction forces})$$

Note:

1. Vector equation
2. \underline{n} = outward unit normal: $\underline{V}_R \cdot \underline{n} < 0$ inlet, > 0 outlet
3. 1D Momentum flux, fixed CV

$$\int_{CS} \underline{V} \rho \underline{V} \cdot \underline{n} dA = \sum (\dot{m}_i \underline{V}_i)_{out} - \sum (\dot{m}_i \underline{V}_i)_{in}$$

Where \underline{V}_i , ρ_i are assumed uniform over fixed discrete inlets and outlets.

$$\dot{m}_i = \rho_i V_{ni} A_i$$

$$\sum \underline{F} = \frac{d}{dt} \int_{CV} \underline{V} \rho dV + \underbrace{\sum (\dot{m}_i \underline{V}_i)_{out}}_{\text{outlet momentum flux}} - \underbrace{\sum (\dot{m}_i \underline{V}_i)_{in}}_{\text{inlet momentum flux}}$$

4. Momentum flux correction factors

$$\int u \rho \underline{V} \cdot \underline{n} dA = \underbrace{\rho \int u^2 dA}_{\text{axial flow with non-uniform velocity profile}} = \rho \beta A V_{av}^2 = \dot{m} \beta V_{av}$$

Where

$$\beta = \frac{1}{A} \int_{CS} \left(\frac{u}{V_{av}} \right)^2 dA$$

$$V_{av} = \frac{1}{A} \int_{CS} u dA = Q/A$$

$$\dot{m} = \rho A V_{av}$$

Laminar pipe flow:

$$u = U_0 \left(1 - \frac{r^2}{R^2} \right) \approx U_0 \left(1 - \frac{r}{R} \right)^{\frac{1}{2}}$$

$$V_{av} = .53U_0 \quad \beta = \frac{4}{3} = 1.33 \quad V_{av} \text{ small and } \beta > 1$$

Turbulent pipe flow:

$$u = U_0 \left(1 - \frac{r}{R} \right)^m \quad \frac{1}{9} \leq m \leq \frac{1}{5}$$

$$V_{av} = U_0 \frac{2}{(1+m)(2+m)} : \text{ for } m = 1/7, \quad V_{av} = .82U_0$$

$$\beta = \frac{(1+m)^2(2+m)^2}{2(1+2m)(2+2m)} : \text{ for } m=1/7, \quad \beta = 1.02$$

$$V_{av} \text{ large } \approx 1 \text{ and } \beta \rightarrow 1$$

5. Constant p causes no force; Therefore,

Use $p_{\text{gage}} = p_{\text{atm}} - p_{\text{absolute}}$

$$\underline{F}_p = - \int_{CS} p \underline{n} dA = - \int_{CV} \nabla p d\forall = 0 \quad \text{for } p = \text{constant}$$

6. For jets open to atmosphere: $p = p_a$, i.e., $p_{\text{gage}} = 0$.

7. Choose CV carefully with CS normal to flow (if possible) and indicating coordinate system and $\Sigma \underline{F}$ on CV similar as free body diagram used in dynamics.

8. Many applications, usually with continuity and energy equations. Careful practice is needed for mastery.

- a. Steady and unsteady developing and fully developed pipe flow
- b. Emptying or filling tanks
- c. Forces on transitions
- d. Forces on fixed and moving vanes.
- e. Hydraulic jump
- f. Boundary Layer and bluff body drag.
- g. Rocket or jet propulsion
- h. Nozzle
- i. Propeller
- j. Water-hammer

P3.53 Consider incompressible flow in the entrance of a circular tube, as in Fig. P3.53. The inlet flow is uniform, $u_1 = U_0$. The flow at section 2 is developed pipe flow.

Find the wall drag force F as a function of (p_1, p_2, ρ, U_0, R) if the flow at section 2 is

(a) Laminar: $u_2 = u_{\max} \left(1 - \frac{r^2}{R^2}\right) \approx u_{\max} (1 - 7r/R)^{1/2}$

(b) Turbulent: $u_2 \approx u_{\max} \left(1 - \frac{r}{R}\right)^{1/7}$

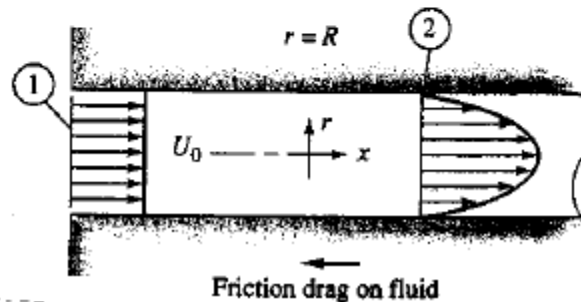

P3.53

First relate u_{\max} to U_0 using continuity equation

$$-Q_{in} + Q_{out} = 0 \Rightarrow Q_{in} = Q_{out} = Q \Rightarrow V_{av,in} = V_{av,out}; \quad V_{av} = \frac{Q}{A}$$

$$U_0 \pi R^2 = \int_0^R u_{\max} \left(1 - \frac{r}{R}\right)^m 2\pi r dr$$

$$U_0 = \frac{1}{\pi R^2} \int_0^R u_{\max} \left(1 - \frac{r}{R}\right)^m 2\pi r dr = V_{av}$$

$$V_{av} = u_{\max} \frac{2}{(1+m)(2+m)}$$

$m = 1/2 \quad V_{av} = .53u_{\max} \quad \rightarrow \quad u_{\max} = V_{av}/.53$

$m = 1/7 \quad V_{av} = .82u_{\max} \quad \rightarrow \quad u_{\max} = V_{av}/.82$

Second, calculate F using momentum equation:

$$F = \text{wall drag force} = \tau_w 2\pi R dx \text{ (force fluid on wall)}$$

$$-F = \text{force wall on fluid}$$

$$\Sigma F_x = (p_1 - p_2)\pi R^2 - F = \int_0^R u_2 (\rho u_2 2\pi r dr) - U_0 (\rho \pi R^2 U_0)$$

$$F = (p_1 - p_2)\pi R^2 + \rho U_0^2 \pi R^2 - \underbrace{\int_0^R \rho u_2^2 2\pi r dr}_{\beta \rho A V_{av}^2}$$

$$F = (p_1 - p_2)\pi R^2 + \underbrace{\rho U_0^2 \pi R^2 - \beta_2 \rho A V_{av}^2}_{\rho U_0^2 \pi R^2 (1 - \beta_2)} \leftarrow = U_0^2 \text{ from continuity}$$

$$\beta = \frac{1}{A} \int \left(\frac{u}{V_{av}} \right)^2 dA$$

momentum flux correction factor

$$= 4/3 \text{ laminar flow}$$

$$= 1.02 \text{ turbulent flow}$$

$$F_{lam} = (p_1 - p_2)\pi R^2 - \frac{1}{3} \rho U_0^2 \pi R^2$$

$$F_{turb} = (p_1 - p_2)\pi R^2 - .02 \rho U_0^2 \pi R^2$$

Complete analysis using BL theory or CFD!

Reconsider the problem for fully developed flow:

Continuity:

$$\begin{aligned}
 -\dot{m}_{in} + \dot{m}_{out} &= 0 \\
 \dot{m} = \dot{m}_{in} = \dot{m}_{out} &\quad \text{or} \quad Q = \text{constant}
 \end{aligned}$$

Momentum:

$$\begin{aligned}
 \sum F_x &= (p_1 - p_2)\pi R^2 - F = \rho \int_{in} u(\underline{V} \cdot \underline{n}) dA + \rho \int_{out} u(\underline{V} \cdot \underline{n}) dA \\
 &= -\rho(\beta AV_{ave}^2)_{in} + \rho(\beta AV_{ave}^2)_{out} \\
 &= \rho Q V_{ave} (\beta_{out} - \beta_{in}) \\
 &= 0
 \end{aligned}$$

$$(p_1 - p_2)\pi R^2 - \tau_w 2\pi R dx = 0$$

$$\Delta p \pi R^2 - \tau_w 2\pi R dx = 0$$

Since $\Delta p = p_1 - p_2 = -dp = -(p_2 - p_1)$

$$\tau_w = \frac{R}{2} \left(-\frac{dp}{dx} \right) \text{ or for smaller CV } r < R, \tau = \frac{r}{2} \left(-\frac{dp}{dx} \right)$$

(Valid for laminar or turbulent flow, but assume laminar)

$\frac{dp}{dx} < 0$ favorable pressure gradient, i.e., $\Delta p = p_1 - p_2 = -dp > 0$

$\frac{dp}{dx} > 0$ adverse pressure gradient, i.e., $\Delta p = p_1 - p_2 = -dp < 0$

$$\tau = \mu \frac{du}{dy} = -\mu \frac{du}{dr} = \frac{r}{2} \left(-\frac{dp}{dx} \right) \quad y = R-r \text{ (wall coordinate)}$$

$$\frac{du}{dr} = -\frac{r}{2\mu} \left(-\frac{dp}{dx} \right)$$

$$u = -\frac{r^2}{4\mu} \left(-\frac{dp}{dx} \right) + c$$

$$u(r = R) = 0 \quad \rightarrow \quad c = \frac{R^2}{4\mu} \left(-\frac{dp}{dx} \right)$$

$$u(r) = \frac{R^2 - r^2}{4\mu} \left(-\frac{dp}{dx} \right) \text{ (If } \frac{dp}{dx} < 0 \text{ flow moves from left to right)}$$

$$u_{\max} = \frac{R^2}{4\mu} \left(-\frac{dp}{dx} \right) \quad u(r) = u_{\max} \left(1 - \frac{r^2}{R^2} \right)$$

$$Q = \int_0^R u(r) 2\pi r \, dr = \frac{\pi R^4}{8\mu} \left(-\frac{dp}{dx} \right)$$

$$V_{ave} = \frac{Q}{A} = \frac{R^2}{8\mu} \left(-\frac{dp}{dx} \right) = u_{\max} / 2$$

$$\tau_w = \frac{R}{2} \left(-\frac{dp}{dx} \right) = \frac{R}{2} \left(\frac{8\mu V_{ave}}{R^2} \right) = \frac{4\mu V_{ave}}{R}$$

$$f = \frac{8\tau_w}{\rho V_{ave}^2} = \frac{32\mu}{\rho R V_{ave}} = \frac{64\mu}{\rho V_{ave} D} = \frac{64}{\text{Re}}$$

$$\text{Re} = \frac{V_{ave} D}{\nu}$$

Exact solution NS for laminar fully developed pipe flow!

Piezometric head

$$h = z + \frac{p}{\gamma}$$

For a horizontal pipe

$$\Delta p = \gamma \Delta h, \quad \Delta z = 0$$

$$\frac{2 dx \tau_w}{R} = -dp = \Delta p = \frac{2 L \tau_w}{R}, \quad f = \frac{8\tau_w}{\rho V_{av}^2}$$

$$\Delta p = \frac{2L\rho V_{av}^2 f}{8R} = \frac{L\rho V_{av}^2 f}{2D}$$

Dividing by γ

$$\frac{\Delta p}{\gamma} = \frac{L\rho V_{av}^2 f}{2D\gamma} = f \frac{L}{D} \frac{V_{av}^2}{2g}$$

More generally

$$\Delta h = f \frac{L}{D} \frac{V_{av}^2}{2g} \quad \text{Darcy-Weisbach equation}$$

Application of relative inertial coordinates for a moving but non-deforming control volume (CV)

The CV moves at a constant velocity \underline{V}_{CS} with respect to the absolute inertial coordinates. If \underline{V}_R represents the velocity in the relative inertial coordinates that move together with the CV, then:

$$\underline{V}_R = \underline{V} - \underline{V}_{CS}$$

Reynolds transport theorem for an arbitrary moving deforming CV:

$$\frac{dB_{SYS}}{dt} = \frac{d}{dt} \int_{CV} \beta \rho d\forall + \int_{CS} \beta \rho \underline{V}_R \cdot \underline{n} dA$$

For a non-deforming CV moving at constant velocity, RTT for incompressible flow:

$$\frac{dB_{syst}}{dt} = \rho \int_{CV} \frac{\partial \beta}{\partial t} d\forall + \rho \int_{CS} \beta \underline{V}_R \cdot \underline{n} dA$$

1. Conservation of mass

$B_{syst} = M$, and $\beta = 1$:

$$\begin{aligned} \frac{dM}{dt} = 0 &= \frac{d}{dt} \int_{CV} \rho d\forall + \int_{CS} \rho \underline{V}_R \cdot \underline{n} dA \\ - \frac{d}{dt} \int_{CV} \rho d\forall &= \int_{CS} \rho \underline{V}_R \cdot \underline{n} dA \end{aligned}$$

For steady flow and $\rho = \text{constant}$:

$$\int_{CS} \underline{V}_R \cdot \underline{n} dA = 0$$

2. Conservation of momentum

$$B_{syst} = M(\underline{V}_R + \underline{V}_{CS}) \text{ and } \beta = dB_{syst}/dM = \underline{V}_R + \underline{V}_{CS} = \underline{V}$$

$$\frac{d[M(\underline{V}_R + \underline{V}_{CS})]}{dt} = \sum \underline{F} = \rho \int_{CV} \frac{\partial(\underline{V}_R + \underline{V}_{CS})}{\partial t} dV + \rho \int_{CS} (\underline{V}_R + \underline{V}_{CS}) \underline{V}_R \cdot \underline{n} dA$$

For steady flow with the use of continuity:

$$\begin{aligned} \sum \underline{F} &= \rho \int_{CS} (\underline{V}_R + \underline{V}_{CS}) \underline{V}_R \cdot \underline{n} dA \\ &= \rho \int_{CS} \underline{V}_R \underline{V}_R \cdot \underline{n} dA + \rho \underline{V}_{CS} \int_{CS} \underline{V}_R \cdot \underline{n} dA^0 \end{aligned}$$

(since $\underline{V}_{CS} = \text{constant}$ and using continuity)

$$\sum \underline{F} = \rho \int_{CS} \underline{V}_R \underline{V}_R \cdot \underline{n} dA$$

Example (use relative inertial coordinates):

A jet strikes a vane which moves to the right at constant velocity V_c on a frictionless cart. Compute (a) the force F_x required to restrain the cart and (b) the power P delivered to the cart. Also find the cart velocity for which (c) the force F_x is a maximum and (d) the power P is a maximum.

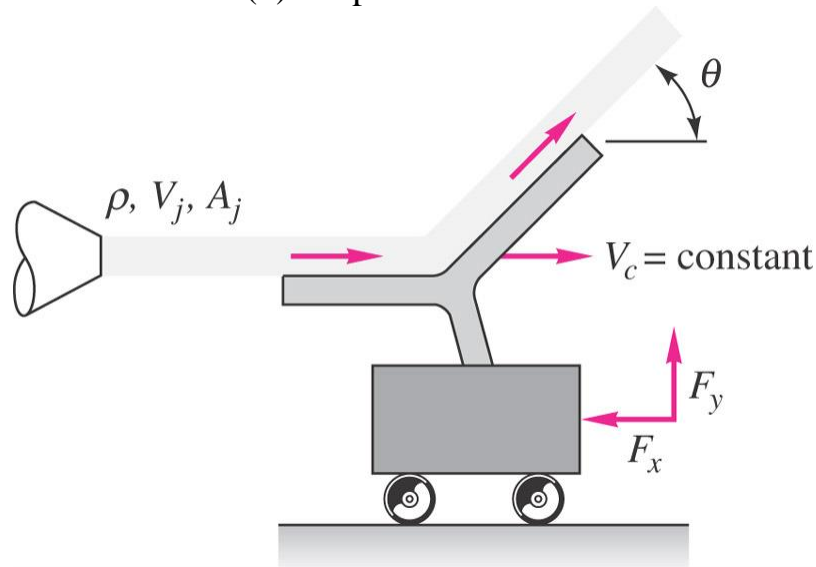

Solution:

Assume relative inertial coordinates with non-deforming CV i.e. CV moves at constant translational non-accelerating

$$\underline{V}_{CS} = u_{CS}\hat{i} + v_{CS}\hat{j} + w_{CS}\hat{k} = V_c\hat{i}$$

then $\underline{V}_R = \underline{V} - \underline{V}_{CS}$. Also assume steady flow $\underline{V} \neq \underline{V}(t)$ with $\rho = \text{constant}$ and neglect gravity effect.

Continuity:

$$\begin{aligned} 0 &= \rho \int_{CS} \underline{V}_R \cdot \underline{n} dA \\ -\rho V_{R1} A_1 + \rho V_{R2} A_2 &= 0 \\ V_{R1} A_1 = V_{R2} A_2 &= \underbrace{(V_j - V_c)}_{V_{R1} = V_{R2} = V_j - V_c} A_j \end{aligned}$$

Bernoulli without gravity:

$$\begin{aligned} \cancel{p}_1^0 + \frac{1}{2} \rho V_{R1}^2 &= \cancel{p}_2^0 + \frac{1}{2} \rho V_{R2}^2 \\ V_{R1} &= V_{R2} \end{aligned}$$

$$A_1 = A_2 = A_j$$

Momentum:

$$\begin{aligned} \underline{\Sigma F} &= \rho \int_{CS} \underline{V_R} \underline{V_R} \cdot \underline{n} dA \\ \Sigma F_x &= -F_x = \rho \int_{CS} V_{Rx} \underline{V_R} \cdot \underline{n} dA \end{aligned}$$

$$-F_x = \rho V_{Rx1}(-V_{R1}A_1) + \rho V_{Rx2}(V_{R2}A_2)$$

$$-F_x = \rho(V_j - V_C)[-(V_j - V_C)A_j] + \rho(V_j - V_C) \cos \theta (V_j - V_C)A_j$$

$$F_x = \rho(V_j - V_C)^2 A_j [1 - \cos \theta]$$

$$Power = V_C F_x = V_C \rho (V_j - V_C)^2 A_j (1 - \cos \theta)$$

$$F_{x_{max}} = \rho V_j^2 A_j (1 - \cos \theta), \quad V_C = 0$$

$$P_{max} \Rightarrow \frac{dP}{dV_C} = 0$$

$$\begin{aligned} P &= V_C \rho (V_j^2 - 2V_C V_j + V_C^2) A_j (1 - \cos \theta) \\ &= \rho (V_j^2 V_C - 2V_C^2 V_j + V_C^3) A_j (1 - \cos \theta) \end{aligned}$$

$$\frac{dP}{dV_C} = \rho (V_j^2 - 4V_C V_j + 3V_C^2) A_j (1 - \cos \theta) = 0$$

$$3V_C^2 - 4V_j V_C + V_j^2 = 0$$

$$V_C = \frac{+4V_j \pm \sqrt{16V_j^2 - 12V_j^2}}{6} = \frac{4V_j \pm 2V_j}{6}$$

$$\text{For } V_C = \frac{V_j}{3}: P_{max} = \frac{V_j}{3} \rho \left(\frac{2V_j}{3}\right)^2 A_j (1 - \cos \theta) = \frac{4}{27} V_j^3 \rho A_j (1 - \cos \theta)$$

Example (use absolute inertial and relative inertial coordinates)

P3.51 A liquid jet of velocity V_j and area A_j strikes a single 180° bucket on a turbine wheel rotating at angular velocity Ω ,

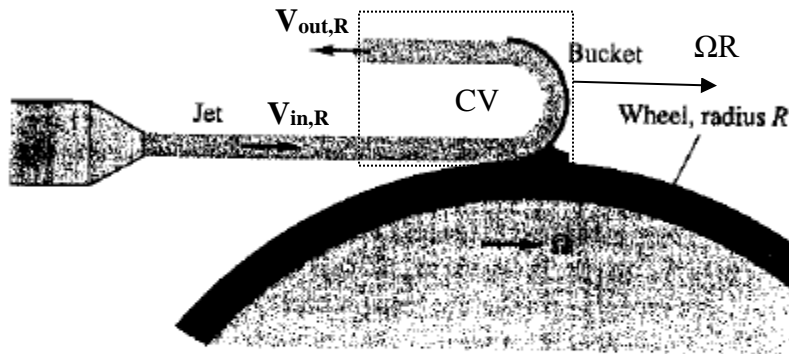

P3.51

as in Fig. P3.51. Derive an expression for the power P delivered to this wheel at this instant as a function of the system parameters. At what angular velocity is the maximum power delivered? How would your analysis differ if there were many, many buckets on the wheel, so that the jet was continually striking at least one bucket?

Assume gravity force is negligible and the cross section area of the jet does not change after striking the bucket. Taking moving CV at speed $\underline{V}_s = \Omega R \hat{i}$ enclosing jet and bucket:

Solution 1 (relative inertial coordinates)

Continuity: $-\dot{m}_{in,R} + \dot{m}_{out,R} = 0$

$$\dot{m}_R = \dot{m}_{in,R} = \dot{m}_{out,R} = \rho \int_{CS} \underline{V}_R \cdot \underline{n} dA$$

Bernoulli without gravity:

$$p_1^0 + \frac{1}{2} \rho V_{in,R}^2 = p_2^0 + \frac{1}{2} \rho V_{out,R}^2$$

$$V_{in,R} = V_{out,R}$$

Inlet $\underline{V}_{in,R} = (V_j - \Omega R) \hat{i}$

Outlet $\underline{V}_{out,R} = -(V_j - \Omega R) \hat{i}$

Since $-\rho V_{in,R} A_1 + \rho V_{out,R} A_2 = 0$
 $A_1 = A_2 = A_j$

Momentum:

$$\sum F_X = -F_{bucket} = \dot{m}_R V_{out,R} - \dot{m}_R V_{in,R}$$

$$F_{bucket} = -\dot{m}_R [-(V_j - \Omega R) - (V_j - \Omega R)]$$

$$= 2\dot{m}_R (V_j - \Omega R)$$

$$= 2\rho A_j (V_j - \Omega R)^2$$

$$\dot{m}_R = \rho A_j (V_j - \Omega R)$$

$$P = \Omega R F_{bucket} = 2\rho A_j \Omega R (V_j - \Omega R)^2$$

$$\frac{dP}{d\Omega} = 2\rho A_j R (V_j - \Omega R)^2 - 2\rho A_j \Omega R 2(V_j - \Omega R) R$$

$$= 2\rho A_j R [(V_j - \Omega R)^2 - 2R\Omega(V_j - \Omega R)]$$

$$= 2\rho A_j R (V_j - \Omega R) [V_j - \Omega R - 2R\Omega]$$

$$\frac{dP}{d\Omega} = 0 \rightarrow V_j - 3\Omega R = 0 \rightarrow \frac{V_j}{3} = \Omega R$$

$$P_{max} = 2\rho A_j \frac{V_j}{3} \left(V_j - \frac{V_j}{3}\right)^2 = 2\rho A_j \frac{V_j}{3} \frac{4V_j^2}{9} = \frac{8}{\underbrace{27}_{0.296}} \rho A_j V_j^3$$

If infinite number of buckets: $\dot{m}_R = \rho A_j V_j$

$$F_{bucket} = 2\rho A_j V_j (V_j - \Omega R)$$

all jet mass flow
 result in work.

$$P = 2\rho A_j V_j \Omega R (V_j - \Omega R)$$

$$\frac{dP}{d\Omega} = 0 \quad \text{for} \quad \Omega R = \frac{V_j}{2} \quad P_{\max} = \frac{1}{2} \rho A_j V_j^3$$

Solution 2 (absolute inertial coordinates)

$$\underline{V}_R = \underline{V} - \underline{V}_{CS} \quad \rightarrow \quad \underline{V} = \underline{V}_R + \underline{V}_{CS}$$

$$\underline{V}_{in} = V_j \hat{i}$$

$$\underline{V}_{out} = -(V_j - \Omega R) \hat{i} + \Omega R \hat{i} = -(V_j - 2\Omega R) \hat{i}$$

Continuity: from solution 1

$$-V_{in,R} + V_{out,R} = 0$$

express in the absolute inertial coordinates: $\underline{V}_R = \underline{V} - \underline{V}_{CS}$

$$-(V_j - \Omega R) \hat{i} + (V_j + 2\Omega R - \Omega R) \hat{i} = 0$$

Momentum:

$$\begin{aligned}\sum F_x &= -F_{bucket} = \dot{m}(V_{out} - V_{in}) \\ &= \rho A_j (V_j - \Omega R) [-(V_j - 2\Omega R) - V_j] \\ F_{bucket} &= 2\rho A_j (V_j - \Omega R)^2\end{aligned}$$

Same as Solution 1.

Application of CV continuity equation for steady incompressible flow, fixed CV, one inlet and outlet with $A = \text{constant}$

$$\rho \int_{in} \underline{V} \cdot \underline{n} dA = \rho \int_{out} \underline{V} \cdot \underline{n} dA = \dot{m} = \rho Q$$

$$Q_{in} = Q_{out}$$

$$(V_{ave} A)_{in} = (V_{ave} A)_{out}$$

For $A = \text{constant}$ $(V_{ave})_{in} = (V_{ave})_{out}$

$$\sum \underline{F} = \rho \int_{in} \underline{V} (\underline{V} \cdot \underline{n}) dA + \rho \int_{out} \underline{V} (\underline{V} \cdot \underline{n}) dA$$

Pipe:

$$\sum F_x = \rho \int_{in} u (\underline{V} \cdot \underline{n}) dA + \rho \int_{out} u (\underline{V} \cdot \underline{n}) dA$$

$$= -\rho (\beta A V_{ave}^2)_{in} + \rho (\beta A V_{ave}^2)_{out}$$

$$= \rho Q V_{ave} (\beta_{out} - \beta_{in}) \quad \text{change in shape u}$$

Vane:

$$\sum \underline{F} = \dot{m} (\underline{V}_{out} - \underline{V}_{in}); \quad |V_{out}| = |V_{in}|$$

If $\theta=180$:

$$\sum F_x = \dot{m} (u_{out} - u_{in}) = \dot{m} (-2u_{in})$$

For arbitrary θ :

$$\sum F_x = \dot{m} (u_{out} \cos \theta - u_{in}) = \dot{m} u_{in} (\cos \theta - 1)$$

change in direction u.

Application of differential momentum equation:

1. NS valid both laminar and turbulent flow; however, many orders of magnitude difference in temporal and spatial resolution, i.e., turbulent flow requires very small time and spatial scales.

2. Laminar flow $Re_{crit} = \frac{U\delta}{\nu} \leq \text{about } 2000$
 $Re > Re_{crit}$ instability

3. Turbulent flow $Re_{transition} \geq 10$ or $20 Re_{crit}$

Random motion superimposed on mean coherent structures.

Cascade: energy from large scale dissipates at smallest scales due to viscosity.

Kolmogorov hypothesis for smallest scales

4. No exact solutions for turbulent flow: RANS, DES, LES, DNS (all CFD)

5. 80 exact solutions for simple laminar flows are mostly linear $\underline{v} \cdot \nabla \underline{v} = 0$. Topics of exact analytical solutions:
 - I. Couette (wall/shear-driven) steady flows
 - a. Channel flows
 - b. Cylindrical flows.
 - II. Poiseuille (pressure-driven) steady flows
 - a. Channel flows
 - b. Duct flows
 - III. Combined Couette and Poiseuille steady flows
 - IV. Gravity and free-surface steady flows
 - V. Unsteady flows
 - VI. Suction and injection flows
 - VII. Wind-driven (Ekman) flows
 - VIII. Similarity solutions

6. Also, many exact solutions for low Re linearized creeping motion Stokes flows and high Re nonlinear BL approximations.

7. Can also use CFD for non-simple laminar flows.

8. AFD or CFD requires well posed IBVP; therefore, exact solutions are useful for setup of IBVP, physics, and verification CFD since modeling errors yield $U_{SM} = 0$ and only errors are numerical errors U_{SN} , i.e., assume analytical solution = truth, called analytical benchmark.

Energy Equation:

$$B = E = \text{energy}$$

$$\beta = e = dE/dm = \text{energy per unit mass}$$

Integral Form (fixed CV):

$$\frac{dE}{dt} = \underbrace{\int_{CV} \frac{\partial}{\partial t} (e\rho) dV}_{\text{rate of change E in CV}} + \underbrace{\int_{CS} e\rho \underline{V} \cdot \underline{n} dA}_{\text{rate of outflux E across CS}} = \dot{Q} - \dot{W}$$

↑
↑
↑

Rate of change E
Rate of heat added CV
Rate work done by CV

$$e = \hat{u} + \frac{1}{2}v^2 + gz = \text{internal} + KE + PE$$

$$\dot{Q} = \text{conduction} + \text{convection} + \text{radiation}$$

$$\dot{W} = \dot{W}_{shaft} + \dot{W}_p + \dot{W}_v$$

pump/turbine
pressure
viscous

$$d\dot{W}_p = (p \underline{n} dA) \cdot \underline{V} \quad - \text{pressure force} \times \text{velocity}$$

$$\dot{W}_p = \int_{CS} p (\underline{V} \cdot \underline{n}) dA$$

$$d\dot{W}_v = -\underline{\tau} dA \cdot \underline{V} \quad - \text{viscous force} \times \text{velocity}$$

$$\dot{W}_v = - \int_{CS} \underline{\tau} \cdot \underline{V} dA$$

$$\dot{Q} - \dot{W}_s - \dot{W}_v = \int_{CV} \frac{\partial}{\partial t} (e\rho) dV + \int_{CS} (e + p/\rho) \rho \underline{V} \cdot \underline{n} dA$$

For our purposes, we are interested in steady flow with one inlet and outlet. Also $\dot{W}_v \approx 0$ in most cases; since, $\underline{V} = 0$ at solid surface; on inlet and outlet $\tau_n \sim 0$ since its perpendicular to flow; or for $\underline{V} \neq 0$ and $\tau_{\text{streamline}} \sim 0$ if outside BL.

$$\dot{Q} - \dot{W}_s = \int_{\text{inlet\&outlet}} \left(\hat{u} + \frac{1}{2} V^2 + gz + p/\rho \right) \rho \underline{V} \cdot \underline{n} dA$$

Assume parallel flow with $\underbrace{p/\rho + gz}$ and \hat{u} constant over inlet and outlet.

= constant i.e.,
 hydrostatic pressure
 variation

$$\dot{Q} - \dot{W}_s = (\hat{u} + p/\rho + gz) \int_{\text{inlet\&outlet}} \rho \underline{V} \cdot \underline{n} dA + \frac{\rho}{2} \int_{\text{inlet\&outlet}} V^2 (\underline{V} \cdot \underline{n}) dA$$

$$\begin{aligned} \dot{Q} - \dot{W}_s &= (\hat{u} + p/\rho + gz)_{in} (-\dot{m}_{in}) - \frac{\rho}{2} \int_{in} V_{in}^3 dA_{in} \\ &\quad + (\hat{u} + p/\rho + gz)_{out} (\dot{m}_{out}) + \frac{\rho}{2} \int_{out} V_{out}^3 dA_{out} \end{aligned}$$

Define kinetic energy correction factor.

$$\alpha = \frac{1}{A} \int_A \left(\frac{V}{V_{ave}} \right)^3 dA \rightarrow \frac{\rho}{2} \int_A V^2 (\underline{V} \cdot \underline{n}) dA = \alpha \frac{V_{ave}^2}{2} \dot{m}$$

Laminar flow: $u = U_0 \left(1 - \left(\frac{r}{R} \right)^2 \right)$

$$V_{ave} = 0.5 \quad \beta = 4/3 \quad \alpha = 2$$

Turbulent flow: $u = U_0 \left(1 - \frac{r}{R} \right)^m$

$$\alpha = \frac{(1+m)^3 (2+m)^3}{4(1+3m)(2+3m)}$$

$$m = 1/7 \quad \alpha = 1.058 \quad \text{as with } \beta, \alpha \sim 1 \text{ for turbulent flow}$$

$$\frac{\dot{Q}}{\dot{m}} - \frac{\dot{W}_s}{\dot{m}} = (\hat{u} + p/\rho + gz + \alpha \frac{V_{ave}^2}{2})_{out} - (\hat{u} + p/\rho + gz + \alpha \frac{V_{ave}^2}{2})_{in}$$

Let in = 1, out = 2, $V = V_{ave}$, and divide by g

$$\frac{p_1}{\rho g} + \frac{\alpha_1}{2g} V_1^2 + z_1 + h_p = \frac{p_2}{\rho g} + \frac{\alpha_2}{2g} V_2^2 + z_2 + h_t + h_L$$

$$\frac{\dot{W}_s}{g\dot{m}} = \frac{\dot{W}_t}{g\dot{m}} - \frac{\dot{W}_p}{g\dot{m}} = h_t - h_p$$

Where h_t extracts and h_p adds energy

$$h_L = \frac{1}{g} (\hat{u}_2 - \hat{u}_1) - \frac{\dot{Q}}{\dot{m}g} = \text{head loss}$$

$h_L = \text{thermal energy (other terms represent mechanical energy)}$

$$\dot{m} = \rho A_1 V_1 = \rho A_2 V_2$$

Assuming no heat transfer mechanical energy converted to thermal energy through viscosity and cannot be recovered; therefore, it is referred to as head loss ≥ 0 , which can be shown from 2nd law of thermodynamics.

1D energy equation can be considered as modified Bernoulli equation for h_p , h_t , and h_L .

Application of 1D Energy equation fully developed pipe flow without h_p or h_t .

Recall for horizontal pipe flow using continuity and momentum: $\tau_w = \frac{R}{2} \left(-\frac{dp}{dx} \right)$, i.e., $-\frac{dp}{dx} = \frac{2\tau_w}{R}$

Similarly, for non-horizontal pipe: $-\frac{d}{dx}(p + \gamma z) = \frac{2\tau_w}{R}$

Using energy equation, $L = dx$ and $\hat{p} = p + \gamma z$:

$$h_L = \frac{p_1 - p_2}{\rho g} + (z_1 - z_2) = \frac{L}{\rho g} \left[-\frac{d}{dx}(p + \gamma z) \right] \quad \frac{\alpha_1}{2g} V_1^2 = \frac{\alpha_2}{2g} V_2^2$$

$$h_L = \frac{L}{\rho g} \left(-\frac{d\hat{p}}{dx} \right) = \frac{L}{\rho g} \left(\frac{2\tau_w}{R} \right) \quad (\text{If } \frac{d\hat{p}}{dx} < 0 \text{ flow moves from left to right})$$

Where $\tau_w = \frac{1}{8} f \rho V_{ave}^2$

$$h_L = h_f = f \frac{L}{D} \frac{V_{ave}^2}{2g} \quad \text{Darcy-Weisbach Equation (valid for laminar or turbulent flow)}$$

Where h_f is the friction loss

Also recall for laminar flow that $\tau_w = \frac{4\mu V_{ave}}{R}$

$$f = \frac{8\tau_w}{\rho V_{ave}^2} = \frac{32\mu}{\rho R V_{ave}} = 64 / \text{Re}_D$$

$$\text{Re}_D = V_{ave} D / \nu$$

$$h_L = \frac{32\mu L V_{ave}}{\gamma D^2} \propto V_{ave} \quad \text{exact solution friction loss for laminar pipe flow!}$$

Note:

Po = Poiseuille number = $fRe = 64$ = pure constant, which is the case for all laminar flows regardless duct cross section but with different constant depending on cross section; since, $\tau_w \propto V_{ave}$

For turbulent flow, $Re_{crit} \sim 2000 (2 \times 10^3)$, $Re_{trans} \sim 3000$

$$f = f(Re, k/D) \quad Re = \frac{V_{ave} D}{\nu}, k = \text{roughness}$$

$$\tau_w \text{ and } h_L \propto V_{ave}^2$$

Pipe with minor losses,

$$h_L = h_f + \sum h_m \quad \text{where} \quad h_m = K \frac{V^2}{2g}$$

K = loss coefficient

h_m = “so called” minor losses, e.g., entrance/exit, expansion/contraction, bends, elbows, tees, other fitting, and valves.

P3.149 A jet of alcohol strikes the vertical plate in Fig. P3.149. A force $F \approx 425$ N is required to hold the plate stationary. Assuming there are no losses in the nozzle, estimate (a) the mass flow rate of alcohol and (b) the absolute pressure at section 1.

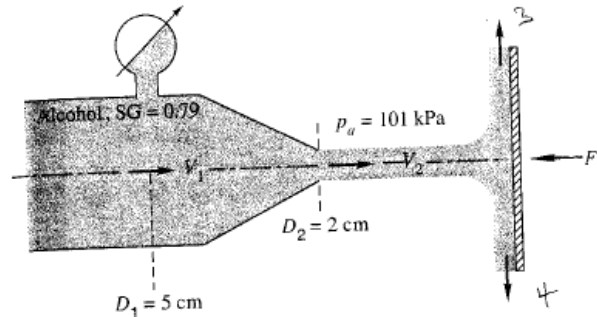

P3.149

(a) First suppose 2D problem: D_1 and D_2 denotes width in y instead of diameter and we take unit length in z (span-wise) direction (know F ; don't know \dot{m} ; use F_x find V_2/\dot{m})

$$\sum F_x = -F = -\dot{m}V_2 \Rightarrow \underbrace{.79 \cdot 989}_{\rho} \times \underbrace{0.02 \times 1}_{A_2} \times V_2^2 = 425N$$

$$V_2 = 5.22 \text{ m/s}, \quad \dot{m} = 81.6 \text{ kg/s}$$

Use continuity and Bernoulli between points 1 and 2 to find p_1 .

$$V_1 A_1 = V_2 A_2 \Rightarrow V_1 = V_2 \frac{D_2}{D_1} = 2.09 \text{ m/s}$$

Bernoulli neglect g , $p_2 = p_a$

$$p_1 + \frac{1}{2} \rho V_1^2 = p_2 + \frac{1}{2} \rho V_2^2 \quad h_L = 0, \quad z = \text{constant}$$

$$p_1 = p_2 + \frac{1}{2} \rho (V_2^2 - V_1^2) \rightarrow p_1 = 101,000 + \frac{.79 \times 998}{2} (5.22^2 - 2.09^2)$$

$$p_1 = 110,020 \text{ Pa} \quad \text{absolute pressure}$$

Note: $p_2 + \frac{\rho}{2} V_2^2 = p_3 + \frac{\rho}{2} V_3^2 = p_4 + \frac{\rho}{2} V_4^2$

$$p_2 = p_3 = p_4 = p_a \rightarrow V_2 = V_3 = V_4$$

$$0 = \sum_{CS} \rho \underline{V} \cdot \underline{A} \rightarrow A_2 V_2 = A_3 V_3 + A_4 V_4$$

$$A_2 = A_3 + A_4$$

$$\begin{aligned} \sum F_y = 0 &= \sum_{CS} \rho V \underline{V} \cdot \underline{A} = \rho V_3 V_3 A_3 + \rho (-V_4) V_4 A_4 \\ &= \rho V_3^2 A_3 - \rho V_4^2 A_4 \rightarrow A_3 = A_4 \end{aligned}$$

(b) For the round jet implied in the problem statement

$$\sum F_x = -F = -\dot{m} V_2 \Rightarrow \underbrace{.79 * 989}_{\rho} \underbrace{\frac{\pi}{4} .02^2}_{A_2} V_2^2 = 425 \text{ N}$$

$$V_2 = 41.4 \text{ m/s}, \quad \dot{m} = 10.3 \text{ kg/s}$$

Continuity equation between points 1 and 2

$$V_1 A_1 = V_2 A_2 \Rightarrow V_1 = V_2 \left(\frac{D_2}{D_1} \right)^2$$

$$V_1 = 41.4 \left(\frac{2}{5} \right)^2 \quad \boxed{V_1 = 6.63 \text{ m/s}}$$

Bernoulli neglect g, $p_2 = p_a$

$$p_1 + \frac{1}{2} \rho V_1^2 = p_2 + \frac{1}{2} \rho V_2^2 \quad h_L = 0, \quad z = \text{constant}$$

$$p_1 = p_2 + \frac{1}{2} \rho (V_2^2 - V_1^2) \rightarrow p_1 = 101,000 + \frac{.79 \times 998}{2} (41.4^2 - 6.63^2)$$

$$\boxed{p_1 = 760,000 \text{ Pa}}$$

Example 7.9

Water is being discharged from a large tank open to the atmosphere through a vertical tube, as shown in Fig. 7.5. The tube is 10 m long, 1 cm in diameter, and its inlet is 1 m below the level of the water in the tank. Find the velocity and the volumetric flowrate in the pipe, assuming:

- a. Frictionless flow.
- b. Laminar viscous flow.

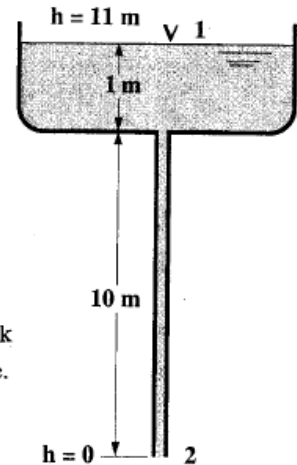

Figure 7.5 Flow from a water tank through a vertical tube.

(a) $z_1 = \frac{V_2^2}{2g} + z_2$ $\alpha_2 = 1, h_L = 0, z_1 = 11, z_2 = 0$

Toricelli's expression for speed of efflux from reservoir

$V_2 = \sqrt{2g(z_1 - z_2)} = \sqrt{2 * 9.81 * 11} = 14.7 \text{ m/s}$

$Q_2 = A_2 V_2 = \frac{\pi}{4} (.01)^2 * 14.7 * 3600 = 4.16 \text{ m}^3 / \text{h}$

$Re = \frac{VD}{\nu} = \frac{14.7 * 0.01}{10^{-6}} = 1.5 * 10^5$

(b) $z_1 = \alpha_2 \frac{V_2^2}{2g} + z_2 + h_L$ $\alpha_2 = 2, h_L = \frac{32VL\mu}{D^2 \rho g}, \nu = 10^{-6} \text{ m}^2 / \text{s}$

$V_2^2 + 3.2V_2 - 107.8 = 0$
 $V_2 = 8.9 \text{ m/s}$
 $Q = 2.516 \text{ m}^3 / \text{h}$

$Re = 89,000 = 8.9 * 10^4 \gg 2000$

$$(c) \quad z_1 = \alpha_2 \frac{V_2^2}{2g} + z_2 + f \frac{L}{D} \frac{V_2^2}{2g} \quad \alpha_2 = 1$$

$$z_1 - z_2 = \frac{V_2^2}{2g} (1 + fL/D)$$

$$V_2 = [2g(z_1 - z_2)/(1 + fL/D)]^{1/2}$$

$$V_2 = [216/(1 + f * 1000)]^{1/2} \quad f = f(\text{Re}), \text{Re} = \frac{VD}{\nu}$$

guess $f = 0.015$ (smooth pipe Moody diagram)

$$V_2 = 3.7 \text{ m/s} \rightarrow \text{Re} = 3.7 \times 10^4, \quad f = .024$$

$$V_2 = 2.94 \text{ m/s} \rightarrow \text{Re} = 2.9 \times 10^4, \quad f = .025$$

$$V_2 = 2.88 \text{ m/s} \rightarrow \text{Re} = 2.9 \times 10^4$$

$$(d) \quad \text{Re} = \frac{VD}{\nu} = 2000 \quad D = \frac{2000\nu}{V}$$

$$(z_1 - z_2) = \alpha_2 \frac{V_2^2}{2g} + \frac{32\nu LV_2}{g \frac{2000^2 \nu^2}{V_2^2}}$$

$$(z_1 - z_2) = \alpha_2 \frac{V_2^2}{2g} + \frac{32\nu LV_2^3}{2000^2 \nu g}$$

$$\frac{32LV_2^3}{2000^2 \nu g} + \frac{V_2^2}{g} - 11 = 0$$

$$V_2 = 1.1 \text{ m/s}$$

$$D = 0.00182 \text{ m}$$

Low U and small D to actually have laminar flow.

Differential Form of Energy Equation:

$$\frac{dE}{dt} = \int_{CV} \left[\underbrace{\frac{\partial}{\partial t}(e\rho) + \nabla \cdot (e\rho \underline{V})}_{=0} \right] dV = \dot{Q} - \dot{W}$$

$$\rho \frac{\partial e}{\partial t} + \underbrace{e \frac{\partial \rho}{\partial t} + e \nabla \cdot (\rho \underline{V})}_{=0} + \rho \underline{V} \cdot \nabla e = \rho \frac{De}{Dt} = \rho \left(\frac{\partial e}{\partial t} + \underline{V} \cdot \nabla e \right)$$

The RHS can be expressed through surface integrals:

$$\dot{Q} = \int_{CS} \underline{q} \cdot \underline{n} dA$$

$$\dot{W} = \int_{CS} \underline{f} \cdot \underline{V} dA$$

$\underline{q} = -k\nabla T$ heat flux
 $\underline{f} = f_j$ = surface forces
 per unit area acting on CS.

And the surface integrals can be converted into volume integrals using Gauss' theorem:

$$\int_{CS} \underline{q} \cdot \underline{n} dA = \int_{CS} q_i n_i dA = \int_{CV} \nabla \cdot \underline{q} dV = \int_{CV} \frac{\partial}{\partial x_i} q_i dV$$

$$\int_{CS} \underline{f} \cdot \underline{V} dA = \int_{CS} \underbrace{n_i \sigma_{ij}}_{=f_j} u_j dA = \int_{CV} \frac{\partial}{\partial x_i} (\sigma_{ij} u_j) dV$$

Where:

$$\nabla \cdot (\sigma_{ij} u_j) = \frac{\partial}{\partial x_i} (\sigma_{ij} u_j) = \frac{\partial}{\partial x_j} (u_i \sigma_{ij})$$

Which enables expressing the energy equation as:

$$\frac{dE}{dt} = \int_{CV} \left[\rho \frac{De}{Dt} \right] dV = \int_{CV} \frac{\partial}{\partial x_i} q_i dV - \int_{CV} \frac{\partial}{\partial x_i} (\sigma_{ij} u_j) dV$$

And in the limit as the CV goes to 0, i.e., for a material volume the differential form per unit volume becomes:

$$\rho \frac{De}{Dt} = (\dot{Q} - \dot{W})/\mathcal{V} = \nabla \cdot \underline{q} - \nabla \cdot (\sigma_{ij} u_j)$$

For the LHS:

$$e = \hat{u} + \frac{1}{2} V^2 + gz = \hat{u} + \frac{1}{2} V^2 - \underline{g} \cdot \underline{r}$$

$$\frac{D(-\underline{g} \cdot \underline{r})}{Dt} = -\underline{g} \cdot \frac{D\underline{r}}{Dt} = -\underline{g} \cdot \underline{V} \quad \boxed{\underline{g} = -g\hat{k}}$$

$$\rho \frac{De}{Dt} = \nabla \cdot \underline{q} - \nabla \cdot (\sigma_{ij} u_j) = \rho \underbrace{\left(\frac{D\hat{u}}{Dt} + V \frac{DV}{Dt} - \underline{g} \cdot \underline{V} \right)}_{\boxed{\frac{De}{Dt}}}$$

All the terms in this equation have dimensions $\left[\frac{N}{m^2 s} \right]$ or equivalently $\left[\frac{kg}{m s^3} \right]$

$$\dot{q} = -\nabla \cdot \underline{q} = \nabla \cdot (k \nabla T) \quad \text{Fourier's Law Heat Conduction}$$

$$\dot{w} = -\nabla \cdot (u_i \sigma_{ij}) = -\frac{\partial}{\partial x_j} (u_i \sigma_{ij}) = -\underline{V} \cdot \underbrace{(\nabla \cdot \sigma_{ij})}_{\rho \left(\frac{DV}{Dt} - \underline{g} \right)} - \sigma_{ij} \frac{\partial u_i}{\partial x_j}$$

using NS

$\nabla \cdot \underline{f} = \text{scalar}$

$\nabla \cdot \sigma_{ij} = \text{vector (decreases 2nd order tensor by one)}$

$$\frac{\partial}{\partial x_j} (u_i \sigma_{ij}) = u_i \frac{\partial \sigma_{ij}}{\partial x_j} + \sigma_{ij} \frac{\partial u_i}{\partial x_j}$$

Total work of surface force	Deformation work w/o <u>a</u> lost to internal energy.	Increase of KE since contributes fluid <u>a</u>
--------------------------------------	---	--

First term for \dot{w}

$$-\underline{V} \cdot (\nabla \cdot \sigma_{ij}) = -\underline{V} \cdot \rho \left(\frac{D\underline{V}}{Dt} - \underline{g} \right) = -\rho \left(\underline{V} \cdot \frac{D\underline{V}}{Dt} - \underline{V} \cdot \underline{g} \right)$$

Where:

$$\underline{V} \cdot \frac{D\underline{V}}{Dt} = \underline{V} \cdot \left(\frac{\partial \underline{V}}{\partial t} + \underline{V} \cdot \nabla \underline{V} \right) = \frac{\partial V^2}{\partial t} + \underline{V} \cdot \nabla V^2 = \frac{DV^2}{Dt} = V \frac{DV}{Dt}$$

Therefore

$$-\underline{V} \cdot (\nabla \cdot \sigma_{ij}) = -\rho \left(V \frac{DV}{Dt} - \underline{V} \cdot \underline{g} \right)$$

And

$$\dot{w} = -\rho \left(V \frac{DV}{Dt} - \underline{V} \cdot \underline{g} \right) - \sigma_{ij} \frac{\partial u_i}{\partial x_j}$$

Substitute equation for \dot{q} and \dot{w}

$$\begin{aligned} \dot{q} - \dot{w} &= -\nabla \cdot (k\nabla T) + \rho \left(\cancel{V \frac{DV}{Dt}} - \underline{V} \cdot \underline{g} \right) + \sigma_{ij} \frac{\partial u_i}{\partial x_j} \\ &= \rho \left(\frac{D\hat{u}}{Dt} + \cancel{V \frac{DV}{Dt}} - \underline{V} \cdot \underline{g} \right) \end{aligned}$$

$$\rho \frac{D\hat{u}}{Dt} = -\nabla \cdot (k\nabla T) + \sigma_{ij} \frac{\partial u_i}{\partial x_j}$$

$$\begin{aligned} \sigma_{ij} &= -p\delta_{ij} + \tau_{ij} \\ \tau_{ij} &= 2\mu\varepsilon_{ij} \\ \varepsilon_{ij} &= \frac{1}{2}(u_{i,j} + u_{j,i}) \end{aligned}$$

Second term on right hand side

$$\sigma_{ij} \frac{\partial u_i}{\partial x_j} = (\tau_{ij} - p\delta_{ij}) \frac{\partial u_i}{\partial x_j} = \tau_{ij} \frac{\partial u_i}{\partial x_j} - p\nabla \cdot \underline{V}$$

From continuity

$$\frac{D\rho}{Dt} + \rho\nabla \cdot \underline{V} = 0 \rightarrow \nabla \cdot \underline{V} = -\frac{1}{\rho} \frac{D\rho}{Dt}$$

$$-p\nabla \cdot \underline{V} = \frac{p}{\rho} \frac{D\rho}{Dt} = -\rho \frac{D}{Dt} \left(\frac{p}{\rho} \right) + \frac{Dp}{Dt}$$

$$\begin{aligned} &-\rho \left[\frac{D}{Dt} \left(\frac{p}{\rho} \right) \right] \\ &= -\rho \frac{1}{\rho} \frac{Dp}{Dt} - \rho p \frac{D}{Dt} \left(\frac{1}{\rho} \right) \\ &= -\frac{Dp}{Dt} + \frac{p}{\rho} \frac{D\rho}{Dt} \\ \\ &\frac{D}{Dt} \left(\frac{1}{\rho} \right) = -\frac{1}{\rho^2} \frac{D\rho}{Dt} \end{aligned}$$

Therefore

$$\sigma_{ij} \frac{\partial u_i}{\partial x_j} = \tau_{ij} \frac{\partial u_i}{\partial x_j} - \rho \frac{D}{Dt} \left(\frac{p}{\rho} \right) + \frac{Dp}{Dt}$$

Such that

$$\rho \frac{D\hat{u}}{Dt} = -\nabla \cdot (k\nabla T) + \tau_{ij} \frac{\partial u_i}{\partial x_j} - \rho \frac{D}{Dt} \left(\frac{p}{\rho} \right) + \frac{Dp}{Dt}$$

Rearranging equation and substituting dissipation

function $\Phi = \tau_{ij} \frac{\partial u_i}{\partial x_j} \geq 0$

$$\rho \frac{D}{Dt} \underbrace{\left(\hat{u} + \frac{p}{\rho} \right)}_{h=\text{enthalpy}} = -\nabla \cdot (k\nabla T) + \frac{Dp}{Dt} + \Phi$$

Consider energy equation in form:

$$\rho \frac{D\hat{u}}{Dt} = -\nabla \cdot (k\nabla T) - p\nabla \cdot \underline{V} + \Phi$$

And compare with mechanical energy equation derived by multiplying u_i x NS:

$$\rho \frac{D\left(\frac{1}{2}u_i^2\right)}{Dt} = \rho \underline{g} \cdot \underline{V} + \frac{\partial(u_i \sigma_{ij})}{\partial x_j} + p\nabla \cdot \underline{V} - \Phi$$

Rate of work done by body force \underline{g}

Total rate of work done σ_{ij}

Rate of work due to volume expansion; converts mechanical energy to internal energy and vice versa

Rate of viscous dissipation

$\Phi \geq 0$ loss mechanical energy = gain internal energy due to deformation of the fluid element

Summary GDE for compressible non-constant property fluid flow

$$\text{Continuity: } \frac{\partial \rho}{\partial t} + \nabla \cdot (\rho \underline{V}) = 0$$

$$\text{Momentum: } \rho \frac{D\underline{V}}{Dt} = \rho \underline{g} - \nabla p + \nabla \cdot \sigma_{ij}$$

$$\sigma_{ij} = 2\mu \epsilon_{ij} + \lambda \nabla \cdot \underline{V} \delta_{ij}$$

$$\underline{g} = -g \hat{k}$$

$$\text{Energy } \rho \frac{Dh}{Dt} = \frac{Dp}{Dt} + \nabla \cdot (k \nabla T) + \Phi$$

Primary variables: p, \underline{V}, T

Auxiliary relations: $\rho = \rho(p, T)$ $\mu = \mu(p, T)$
(equations of state) $h = h(p, T)$ $k = k(p, T)$

Restrictive Assumptions:

- 1) Continuum
- 2) Newtonian fluids
- 3) Thermodynamic equilibrium
- 4) $\underline{g} = -g \hat{k}$
- 5) heat conduction follows Fourier's law.
- 6) no internal heat sources.

For incompressible constant property fluid flow

$$d\hat{u} = c_v dT \quad c_v, \mu, k, \rho \sim \text{constant}$$

$$\rho c_v \frac{DT}{Dt} = k\nabla^2 T + \Phi$$

For static fluid or \underline{V} small

$$\rho c_p \frac{\partial T}{\partial t} = k\nabla^2 T \quad \text{heat conduction equation (also valid for solids)}$$

Summary GDE for incompressible constant property fluid flow ($c_v \sim c_p$)

$$\nabla \cdot \underline{V} = 0$$

$$\rho \frac{D\underline{V}}{Dt} = -\rho g \hat{k} - \nabla p + \mu \nabla^2 \underline{V} \quad \text{“elliptic”}$$

$$\rho c_p \frac{DT}{Dt} = k\nabla^2 T + \Phi \quad \text{where } \Phi = \tau_{ij} \frac{\partial u_i}{\partial x_j}$$

Continuity and momentum uncoupled from energy; therefore, solve separately and use solution post facto to get T.

For compressible flow, ρ solved from continuity equation, T from energy equation, and $p = (\rho, T)$ from equation of state (e.g., ideal gas law). For incompressible flow, $\rho = \text{constant}$ and T uncoupled from continuity and momentum equations, the latter of which contains ∇p such that reference p is arbitrary and specified post facto (i.e., for incompressible flow, there is no connection between p and ρ). The connection is between ∇p and $\nabla \cdot \underline{V} = 0$, i.e., a solution for p requires $\nabla \cdot \underline{V} = 0$.

NS:

$$\frac{\partial u_i}{\partial x_i} = 0$$

$$\rho \left(\frac{\partial u_i}{\partial t} + u_j \frac{\partial u_i}{\partial x_j} \right) = - \frac{\partial p}{\partial x_i} + \mu \frac{\partial^2 u_i}{\partial x_j^2}$$

$\nabla \cdot (NS)$:

$$\nabla \cdot \left[\frac{\partial \underline{V}}{\partial t} + \underline{V} \cdot \nabla \underline{V} = - \nabla \left(\frac{p}{\rho} \right) + \nu \nabla^2 \underline{V} \right]$$

$$\nabla \cdot \left(\frac{\partial \underline{V}}{\partial t} - \nu \nabla^2 \underline{V} \right) + \nabla \cdot (\underline{V} \cdot \nabla \underline{V}) = - \nabla^2 \left(\frac{p}{\rho} \right)$$

$$\left(\frac{\partial}{\partial t} - \nu \nabla^2 \right) \nabla \cdot \underline{V} + \nabla \cdot (\underline{V} \cdot \nabla \underline{V}) = - \nabla^2 \left(\frac{p}{\rho} \right)$$

$$\underline{V} \cdot \nabla \underline{V} = u_j \frac{\partial u_i}{\partial x_j}$$

$$\nabla \cdot (\underline{V} \cdot \nabla \underline{V}) = \frac{\partial}{\partial x_i} \left(u_j \frac{\partial u_i}{\partial x_j} \right) = \frac{\partial u_j}{\partial x_i} \frac{\partial u_i}{\partial x_j} + u_j \frac{\partial}{\partial x_i} \frac{\partial u_i}{\partial x_j}$$

$$\nabla \cdot (\underline{V} \cdot \nabla \underline{V}) = \frac{\partial u_j}{\partial x_i} \frac{\partial u_i}{\partial x_j}$$

$$\left(\frac{\partial}{\partial t} - \nu \nabla^2 \right) \nabla \cdot \underline{V} = -\frac{1}{\rho} \nabla^2 p - \frac{\partial u_i}{\partial x_j} \frac{\partial u_j}{\partial x_i}$$

For $\nabla \cdot \underline{V} = 0$:

$$\nabla^2 p = -\rho \frac{\partial u_i}{\partial x_j} \frac{\partial u_j}{\partial x_i}$$

Poisson equation determines pressure up to additive constant.

Approximate Models:

1) Stokes Flow

For low $Re = \frac{UL}{\nu} \ll 1$, $\underline{V} \cdot \nabla \underline{V} \sim 0$

$$\begin{array}{l} \nabla \cdot \underline{V} = 0 \\ \frac{\partial \underline{V}}{\partial t} = -\frac{1}{\rho} \nabla p + \nu \nabla^2 \underline{V} \end{array} \quad \left. \begin{array}{l} \phantom{\frac{\partial \underline{V}}{\partial t} = -\frac{1}{\rho} \nabla p + \nu \nabla^2 \underline{V}} \\ \phantom{\frac{\partial \underline{V}}{\partial t} = -\frac{1}{\rho} \nabla p + \nu \nabla^2 \underline{V}} \end{array} \right\} \begin{array}{l} \text{Linear, "elliptic"} \\ \text{Most exact solutions NS; and for steady} \\ \text{flow superposition, elemental solutions,} \\ \text{and separation of variables} \end{array}$$

$$\nabla \cdot (NS) \Rightarrow \nabla^2 p = 0$$

2) Boundary Layer Equations

For high $Re \gg 1$ and attached boundary layers or fully developed free shear flows (wakes, jets, mixing layers),

$\nu \ll U$, $\frac{\partial}{\partial x} \ll \frac{\partial}{\partial y}$, $p_y = 0$, and for free shear flow $p_x = 0$.

$$u_x + v_y = 0$$

$$u_t + uu_x + vu_y = -\hat{p}_x + \nu u_{yy} \quad \text{non-linear, "parabolic"}$$

$$p_y = 0$$

$$-\hat{p}_x = U_t + UU_x$$

Many exact solutions; similarity methods

3) Inviscid Flow

$$\frac{\partial \rho}{\partial t} + \nabla \cdot (\rho \underline{V}) = 0$$

$$\rho \frac{D\underline{V}}{Dt} = \rho \underline{g} - \nabla p \quad \text{Euler Equation, nonlinear, "hyperbolic"}$$

$$\rho \frac{Dh}{Dt} = \frac{Dp}{Dt} + \nabla \cdot (k \nabla T) \quad p, \underline{V}, T \text{ unknowns and } \rho, h, k = f(p, T)$$

4) Inviscid, Incompressible, Irrotational

$$\begin{aligned} \nabla \times \underline{V} &= 0 \rightarrow \underline{V} = \nabla \varphi \\ \nabla \cdot \underline{V} &= 0 \rightarrow \nabla^2 \varphi = 0 \quad \text{linear elliptic} \end{aligned}$$

∫ Euler Equation → Bernoulli Equation:

$$p + \frac{\rho}{2} V^2 + \rho g z = \text{const}$$

Many elegant solutions: Laplace equation using superposition elementary solutions, separation of variables, complex variables for 2D, and Boundary Element methods.

Couette Shear Flows: 1-D shear flow between surfaces of like geometry (parallel plates or rotating cylinders).

Steady Incompressible Flow Between Parallel Plates: *Combined Couette and Poiseuille Flow*. IBVP: geometry, conditions, domain/coordinate system, GDE, and IC/BC)

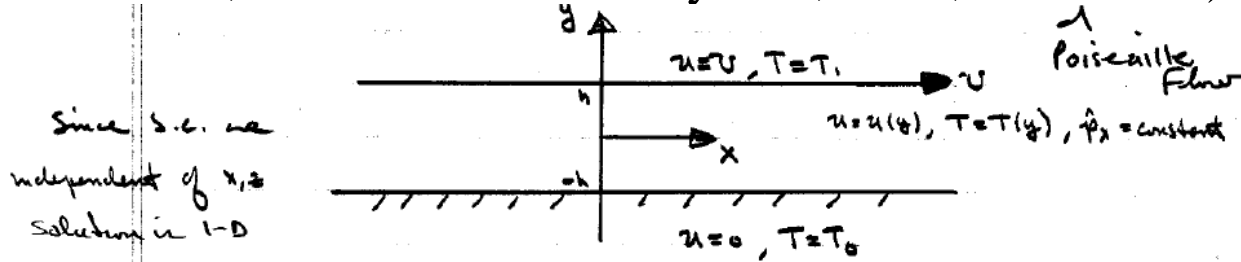

$$\nabla \cdot \underline{V} = 0$$

$$u_x + v_y + w_z = 0$$

$$u_x = 0 \quad \text{i.e., fully developed flow}$$

$$\rho \frac{DV}{Dt} = -\nabla \hat{p} + \mu \nabla^2 \underline{V}$$

$$\frac{\partial u}{\partial t} + uu_x + vu_y + wu_z = 0$$

$$0 = -\hat{p}_x + \mu u_{yy}$$

$$\rho c_p \frac{DT}{Dt} = k \nabla^2 T + \Phi$$

$$\frac{\partial T}{\partial t} + uT_x + vT_y + wT_z = 0$$

$$\begin{aligned} \Phi &= \tau_{ij} \frac{\partial u_i}{\partial x_j} = \mu (u_{i,j} + u_{j,i}) \frac{\partial u_i}{\partial x_j} \\ &= \mu [2u_x^2 + 2v_y^2 + 2w_z^2 \\ &\quad + (v_x + u_y)^2 + (w_y + v_z)^2 + (u_z + w_x)^2] \\ &= \mu u_y^2 \end{aligned}$$

$$0 = kT_{yy} + \mu u_y^2$$

(Note inertia terms vanish identically and ρ is absent from equations)

*Non-dimensional equations, but drop **

$$u^* = u/U \quad T^* = \frac{T - T_0}{T_1 - T_0} \quad y^* = y/h$$

$$u_x = 0 \tag{1}$$

$$u_{yy} = \frac{h^2}{\mu U} \hat{p}_x = -B = \text{constant} \tag{2}$$

$$T_{yy} = \frac{\mu U^2}{\underbrace{k(T_1 - T_0)}_{PrEc}} [-u_y^2] \tag{3}$$

B.C. $y = 1 \quad u = 1 \quad T = 1$
 $y = -1 \quad u = 0 \quad T = 0$

(1) is consistent with 1-D flow assumption. Simple form of (2) and (3) allow for solution to be obtained by double integration.

$$\Rightarrow u = \underbrace{\frac{1}{2}(1+y)}_{\text{Linear flow due to } U} + \underbrace{\frac{1}{2}B(1-y^2)}_{\text{Parabolic flow due to } p_x} \quad y=y/h$$

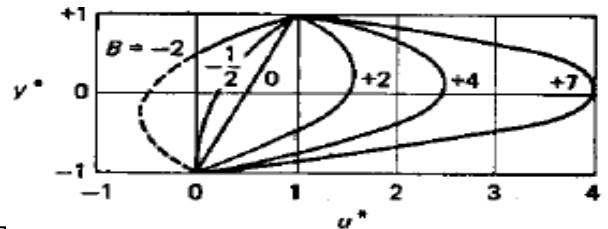

Note: linear superposition since $\underline{V} \cdot \nabla \underline{V} = 0$

Solution depends on $B = -\frac{h^2}{\mu U} \hat{p}_x$ ($\hat{p}_x = \partial p / \partial x + \gamma \partial z / \partial x$)

- $B < 0$ (favorable) \hat{p}_x is opposite to U
- $B < -0.5$ backflow occurs near lower wall
- $|B| \gg 1$ flow approaches parabolic profile.

$$T = \frac{1}{2}(1+y) + \frac{Pr E_c}{8}(1-y^2) + \overbrace{\left[-\frac{Pr E_c B}{6}(y-y^3) + \frac{Pr E_c B^2}{12}(1-y^4) \right]}^{\text{Pressure gradient effect}}$$

Pure conduction

T rises due to viscous dissipation

Dominant term for $B \rightarrow \infty$

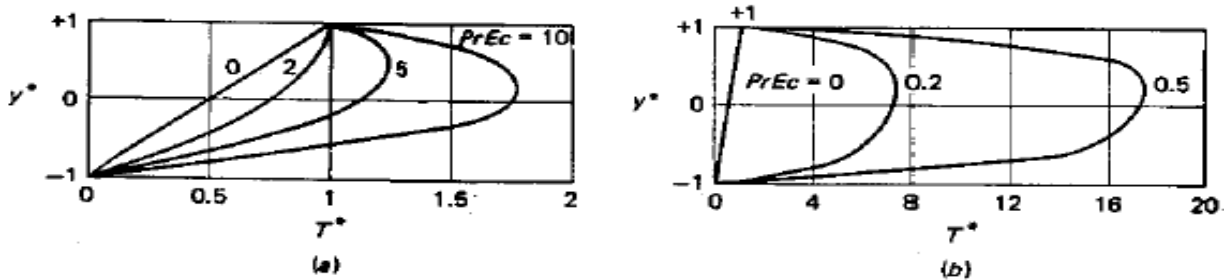

FIGURE 3-3 Temperature distributions for flow between parallel plates, Eq. (3-12): (a) pure Couette flow: $B = 0$; (b) mostly Poiseuille flow: $B = 20$.

Note: usually PrE_c is quite small

Substance	PrE_c	dissipation
Air	0.001	very small
Water	0.02	
Crude oil	20	large

$$Br = Pr E_c = \text{Brinkman \#}$$

Prandtl number $Pr = \mu C_p / k = \text{momentum diffusivity} / \text{thermal diffusivity}$

Eckert number $Ec = U^2 / C_p (T_1 - T_0) = \text{advection transport} / \text{heat dissipation potential}$

$Br\# = \text{heat produced viscous dissipation} / \text{heat transported molecular conduction}$

Shear Stress

1) $\hat{p}_x = 0$ i.e., pure Couette Flow

$$B = -\frac{h^2}{\mu U} \hat{p}_x = 0$$

Using solution shown previously

$$u^* = \frac{1}{2}(1 + y^*) + \frac{1}{2}B(1 - y^{*2}) = \frac{1}{2}(1 + y^*)$$

Calculating wall shear stress

$$\frac{u}{U} = \frac{1}{2} \left(1 + \frac{y}{h} \right)$$

$$\frac{\partial \left(\frac{u}{U} \right)}{\partial \left(\frac{y}{h} \right)} = \frac{1}{2}$$

$$\tau_w = \mu \left. \frac{du}{dy} \right|_{y=-1} = \frac{\mu U}{2h}$$

$$C_f = \frac{\tau_w}{\frac{1}{2}\rho U^2} = \frac{\frac{\mu U}{2h}}{\frac{1}{2}\rho U^2} = \frac{\mu}{\rho U h}$$

Since $Re_h = \rho U h / \mu$

$$C_f = \frac{1}{Re_h}$$

$P_0 = C_f Re = 1$: Better for non-accelerating flows
since ρ is not in equations and $P_0 =$ pure constant

2) $U = 0$ i.e. pure Poiseuille Flow

$$u^* = \frac{1}{2} B(1 - y^{*2}) \quad u_y^* = -By^* \quad u_y = -\frac{BU}{h^2} y \quad V_{ave} = \bar{u}$$

Where $B = \frac{-h}{\mu U} \hat{p}_x = \frac{2u_{max}}{U}$

Dimensional form $u = \underbrace{-\frac{1}{2} \frac{h^2}{\mu} \hat{p}_x}_{u_{max}} \left(1 - \left(\frac{y}{h} \right)^2 \right) \quad Q = \int_{-h}^h u dy = \frac{4}{3} hu_{max}$

$$\bar{u} = \frac{Q}{2h} = \frac{2}{3} u_{max} = V_{ave}$$

Remember that for laminar pipe flow, $V_{ave} = \frac{1}{2} u_{max}$

$$\tau_w = \mu u_y \Big|_{y=\pm h} = -\mu \frac{BU}{h} \quad \text{upper}$$

$$= +\mu \frac{BU}{h} \quad \text{lower}$$

$$|\tau_w| = \mu \frac{BU}{h} = \mu \frac{2u_{max}}{h} = \mu 3\bar{u}/h \quad \propto \bar{u} \quad \text{lam.}$$

$$\propto \rho u^2 \quad \text{turb.}$$

$$C_f = \frac{\tau_w}{\frac{1}{2} \rho U^2} = \frac{6\mu}{\rho u h} = \frac{6}{Re_h} \quad \text{or} \quad P_0 = C_f Re_h = 6$$

Remember that for laminar pipe flow, $C_f = \frac{16}{Re_D}$ and $\tau_w = \frac{\mu 8V_{ave}}{D}$, i.e., except for numerical constants same functionality as for circular pipe.

Rate of heat transfer at the walls:

$$q_w = \left| k \frac{\partial T}{\partial y} \right|_{y \pm h} = \frac{k}{2h} (T_1 - T_0) \pm \mu \frac{U^2}{4h} \quad + = \text{upper, } - = \text{lower}$$

Heat transfer coefficient:

$$\zeta = \frac{q_w}{(T_1 - T_0)}$$

$$Nu = \frac{2h\zeta}{k} = 1 \pm Br/2$$

For $Br > 2$, both upper & lower walls must be cooled to maintain T_1 and T_0

Conservation of Angular Momentum: moment form of momentum equation (not new conservation law!)

$B = \underline{H}_0 = \int_{sys} \underline{r} \times \underline{V} dm =$ *angular momentum of system about inertial coordinate system 0 (extensive property)*

$$\beta = \frac{dB}{dM} = \underline{r} \times \underline{V} \quad (\text{Intensive property})$$

$$\underbrace{\frac{d\underline{H}_0}{dt}}_{\text{Rate of change of angular momentum}} = \frac{d}{dt} \int_{CV} (\underline{r} \times \underline{V}) \rho dV + \int_{CS} (\underline{r} \times \underline{V}) \rho \underline{V}_R \cdot \underline{n} dA$$

$= \sum \underline{M}_0 =$ *vector sum all external moments applied on CV due to both \underline{F}_B and \underline{F}_S , including reaction forces.*

For uniform flow across discrete inlet/outlet:

$$\int_{CS} (\underline{r} \times \underline{V}) \rho \underline{V}_R \cdot \underline{n} dA = \sum (\underline{r} \times \underline{V})_{out} \dot{m}_{out} - \sum (\underline{r} \times \underline{V})_{in} \dot{m}_{in}$$

$$\underline{M}_0 = \underbrace{\int_{CS} \underline{\tau} \cdot dA \times \underline{r}}_{\text{surface force moment}} + \underbrace{\int_{CV} (\rho \underline{g} dV) \times \underline{r}}_{\text{body force moment}} + \underline{M}_R$$

$$\underline{M}_R = \text{moment of reaction forces}$$

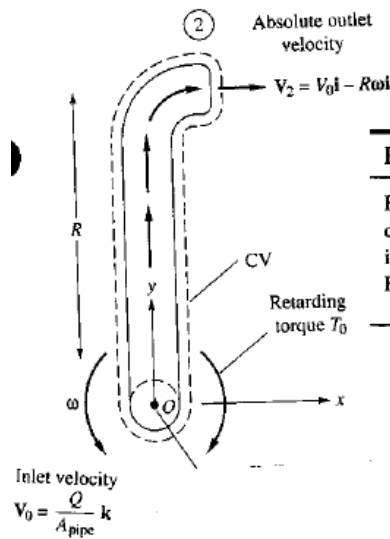

EXAMPLE 3.15

Figure 3.14 shows a lawn sprinkler arm viewed from above. The arm rotates about O at constant angular velocity ω . The volume flux entering the arm at O is Q , and the fluid is incompressible. There is a retarding torque at O , due to bearing friction, of amount $-T_0\hat{k}$. Find an expression for the rotation ω in terms of the arm and flow properties.

Fig. 3.14 View from above of a single arm of a rotating lawn sprinkler.

Take inertial frame O as fixed to earth such that CS moving at $\underline{V}_s = -R\omega \hat{i}$

$$\underline{V} = \underline{V}_R + \underline{V}_S$$

$$\underline{V}_2 = V_0 \hat{i} - R\omega \hat{i} = (V_0 - R\omega) \hat{i} \quad \underline{r}_2 = R \hat{j}$$

$$\underline{V}_1 = V_0 \hat{k} \quad \underline{r}_1 = 0 \hat{j}$$

$$V_0 = \frac{Q}{A_{pipe}}$$

Retarding torque due to bearing friction

$$\sum \underline{M}_Z = 0 = -T_0 \hat{k} = (\underline{r}_2 \times \underline{V}_2) \dot{m}_{out} - (\underline{r}_1 \times \underline{V}_1) \dot{m}_{in}$$

$$\dot{m}_{out} = \dot{m}_{in} = \rho Q \quad -T_0 \hat{k} = R(V_0 - R\omega)(-\hat{k})\rho Q$$

$$\omega = \frac{V_0}{R} - \frac{T_0}{\rho QR^2} \longrightarrow \text{interestingly, even for } T_0=0, \omega_{max}=V_0/R$$

(limited by ratio such that large R small ω ; large V_0 large ω)

Differential Equation of Conservation of Angular Momentum:

Apply CV form for fixed CV:

$$\underline{\Sigma M}_o = \frac{d}{dt} \int_{CV} (\underline{r} \times \underline{v}) \rho dV + \int_{CS} (\underline{r} \times \underline{v}) \rho \underline{v} \cdot \underline{n} dA$$

$\tau_{yx} + \frac{1}{2} \frac{\partial \tau_{yx}}{\partial y} dy$
 $\tau_{xy} - \frac{1}{2} \frac{\partial \tau_{xy}}{\partial x} dx$
 $\tau_{xy} + \frac{1}{2} \frac{\partial \tau_{xy}}{\partial x} dx$
 $\tau_{yx} - \frac{1}{2} \frac{\partial \tau_{yx}}{\partial y} dy$
 $(x, y) = \text{center of mass}$

$\dot{\omega}_z$ = angular acceleration

I = moment of inertia

$$I \dot{\omega}_z = a dy \frac{dx}{2} + b dy \frac{dx}{2} - c dx \frac{dy}{2} - d dx \frac{dy}{2}$$

$$I \dot{\omega}_z = (\tau_{xy} - \tau_{yx}) dxdy$$

Since $I = \frac{\rho}{12} [dxdy^3 + dydx^3] = \frac{\rho}{12} dxdy [dx^2 + dy^2]$

$$\frac{\rho}{12} [dx^2 + dy^2] \dot{\omega}_z = \tau_{xy} - \tau_{yx}$$

$\lim_{dx \rightarrow 0, dy \rightarrow 0} \tau_{xy} = \tau_{yx}$, similarly, $\tau_{xz} = \tau_{zx}$, $\tau_{yz} = \tau_{zy}$

i.e. $\tau_{ij} = \tau_{ji}$ stress tensor is symmetric (stresses themselves cause no rotation)